



*Pearl*®

2 0 2 3  
GENERAL CATALOG



**INSPIRATION AWAITS!**

With nearly eight decades of legendary crafting history firmly cemented in the lives of countless drummers, 2023 sees Pearl advancing the drum set to unsurpassed heights. Our goal was to make the complete selection and performance aspect of drumming effortless and fuel the current of rhythmic creativity in a new generation of players. This would include an odyssey into the very foundations of drum making, from shell formation to mounting platforms, to eliminate stress and let each drum truly sing. The solution lies in reimagining the benefits of tom suspension systems on a new era of professionally catered percussion items, to showcase the sonic and visual identity of each drummer and bridge the gap between Player and Instrument.



**MASTERWORKS**  
p. 3 - 4, 7 - 12

Custom made in your personal selection of woods, edges, sizes, and veneers.  
**SHELL RECIPE**  
Individually tailored combination of Birch, Maple, Gumwood, and/or Mahogany.  
**SOUND**  
The tonal reality of your ultimate ideal, Masterworks literally sounds like every drum set you've ever dreamed of.



**REFERENCE ONE**  
p. 13 - 14

The ultimate ideal of the modern hybrid drum concept, all components are independently engineered for the best tonality in every quadrant of the kit.  
**SHELL RECIPE**  
EvenPly Birch, Maple, and Mahogany hybrid.  
**SOUND**  
Expressive, wide range sonic boost with enhanced bottom-end.



**CRYSTAL BEAT**  
p. 29 - 30

The original seamless Acrylic drum shell creates a striking visual and sonic showcase.  
**SHELL RECIPE**  
Seamless molded Acrylic (Tom and Floor Tom: 6mm / Bass Drum: 7mm)  
**SOUND**  
Loud and immediate, delivers pummeling straight tone and yielding feel.



**DECADE MAPLE**  
p. 31 - 32

Premium gear for the evolving drummer, featuring lacquered all Maple shells and pro-level elements.  
**SHELL RECIPE**  
EvenPly-Six, 5.4mm Maple  
**SOUND**  
Full maple tone with lively midrange and smooth sustain.



**EXPORT**  
p. 33 - 34

The Best-Selling Drum Set of All Time gives the student drummer a strong beginning.  
**SHELL RECIPE**  
6-ply 7.5mm Poplar and Asian Mahogany hybrid  
**SOUND**  
Crisp attack with dark, formidable bottom-end vibrance.



**MASTERS MAPLE / GUM**  
p. 17 - 18

Optimized for the recording studio; vital tone derived from the Masterworks: Studio shell recipe.  
**SHELL RECIPE**  
EvenPly-Six Maple (4-ply outer) and Gumwood (2-ply inner)  
**SOUND**  
Explosive midrange tonality with full low-end and precise decay.



**MASTERS MAPLE**  
p. 19 - 20

Three decades of Masters excellence is reimagined with our history-making 6-ply Maple shell and a host of massive upgrades.  
**SHELL RECIPE**  
7.5mm 6-ply Premium Maple.  
**SOUND**  
Attack and projection with smooth, full-bodied resonant attack.



**MASTERS MAPLE PURE**  
p. 21 - 22

Pearl's original premium MMX shell formula delivers near-field resonance and sharp top-end attack for varied pro environments.  
**SHELL RECIPE**  
5mm 4-ply Premium Maple w/4-ply Reinforcement Rings.  
**SOUND**  
Balance of powerful midrange and smooth resonant attack.



**MIDTOWN**  
p. 35

An ultra-portable shell pack for full-sized play and powerful grooves in a small footprint.  
**SHELL RECIPE**  
6-ply 7.5mm Poplar  
**SOUND**  
Tight, responsive tonal bite with enough bottom to fill the pocket.



**ROADSHOW**  
p. 36

A drum set package complete with everything needed to kickstart your rhythmic journey.  
**SHELL RECIPE**  
9-ply 7mm Poplar  
**SOUND**  
Piercing, open cut with the right amount of sub-bass rumble to keep you inspired.



**PROFESSIONAL SERIES**  
p. 23 - 24

A gig-friendly workhorse derived from our classic MLX Series that's excellent for independent touring.  
**SHELL RECIPE**  
EvenPly-Six, 5.4mm North American Maple  
**SOUND**  
Equal parts Low/Mid/High frequency punch with smooth, extended decay.



**SESSION STUDIO SELECT**  
p. 25 - 26

Radically unique Studio blend with pre-EQ'd warmth and cutting, articulate strike.  
**SHELL RECIPE**  
EvenPly-Six Birch (4-ply outer) and African Mahogany (2-ply inner)  
**SOUND**  
Deep, rich bass frequencies combined with top-end tonal drive.



**PRESIDENT SERIES DELUXE**  
p. 27 - 28

Dark, dry vintage spread with the classically controlled "MJ Sound".  
**SHELL RECIPE**  
6-ply, 7.5mm Lauan.  
**SOUND**  
A slick, sonic locomotive of subdued, vintage punch with singular low-range overtone.

**2023 GENERAL CATALOG**

<b>DRUM SETS</b>	<b>SNARE DRUMS</b>	<b>HARDWARE</b>	<b>PERCUSSION</b>
3-4,7-12 Masterworks	37-39 Series Component	53-54 Demon XR	73 Percussion Artists
5-6 R2 Air Suspension System	40 Free Floating	55 Demon Drive	74 Signature Series
13-14 Reference One	41 SensiTone Heritage Alloy	56 Demon Chain	75-76 Congas & Bongos
15-16 Masters Introduction	42-44 Signature	57-58 Eliminator Redline	77-78 Travel (Congas, Bongos, Timbales)
17-18 Masters Maple/Gum	45 Hybrid Exotic	59-60 Eliminator Solo	77 Timbales
19-20 Masters Maple	45 UltraCast	61 P-930 / P-932	78 Cowbells
21-22 Masters Maple Pure	45 Duoluxe	62 P-920 / P-922 / P-530 / P-830	79 Djembes
23-24 Professional Series	46 StaveCraft	63-64 Hi-Hat Stands	80 Folkloric / Brazilian
25-26 Session Studio Select	47 Modern Utility	65 Snare Stands	81-82 Cajons & Cajon Accessories
27-28 President Series Deluxe	48 Effects	66 Drum Thrones	83 Handpans
29-30 Crystal Beat		67-68 Cymbal Stands	84 Tongue Drums
31-32 Decade Maple		69-70 Racks	85 Rainsticks / Nut Shakers
33-34 Export	<b>ELECTRONIC SERIES</b>	71 Rack Accessories	86 Concert Percussion
35 Midtown	49-50 e/MERGE	72 Tom Stands	87-88 Hand Percussion
35 Rocket Toms	51 MIMIC PRO	72 Tom Arms	89 Percussion Stands
35 Compact Traveler	52 malletSTATION		90 Bags & Holders
36 Roadshow / Roadshow Jr.			
91-94 Replacement Parts	95-98 Pearl Artists	99- <b>BACK</b> Config. & Color Chart	



## Completely Custom, Totally Handmade

### HANDCRAFTED FOR GREATNESS

Masterworks is the realization of your ultimate drum set vision. Every aspect of the kit is curated by you and built to your exacting specifications.



### EXPLORE. CREATE. INSPIRE.

Masterworks begins with your choice of our finest hand selected shell veneers and precision engineered premium hardware appointments. Choose your own combination or one of our Sonic-Select Shell recipes to customize a sound and look that is completely your own.

**MASTERWORKS SONIC-SELECT URBAN RECIPE**  
NATURAL WALNUT BURST BUBINGA AND ROSETTE INLAY

### DRUM SHELL TONE WOODS

Choose one or a combination of our premium shell materials to sculpt the sound of each drum.



**MAPLE**  
Tonally equal in highs, mids, and lows for prime, full bodied attack and sustain.

**BIRCH**  
Boosted attack with "Built-in EQ" for articulate and evenly reduced decay.

**AFRICAN MAHOGANY**  
Dark, elegant tone with powerful bottom-end emphasis.

**GUMWOOD**  
As a core or interior ply, Gum enhances tone in surrounding plies.

**CUSTOM INTERIOR**  
Choose any of Pearl's Artisan Exotic veneers, carbon fiber, or hand applied fiberglass for boutique tones and visuals.

### SHELL SIZE AND THICKNESS

For precise tonal character, sustain, and projection.



**THIN** (4-ply, 5mm w/ 4-ply Reinforcement Rings) Increased sustain and low-end.

**MEDIUM** (Even 6-Ply, 5.4mm) Expanded tonal purity and resonant punch.

**STANDARD** (6-ply, 7.5mm) Full-bodied tonal projection ideal for general purpose.

**THICK** (8-ply, 10mm and 10-ply, 12.5mm) Maximum projection and quick decay.

### FINISHES

Craft an inspired visual statement with drums hand finished and configured to your specifications.

**LUXURY**  
Includes a choice of High Gloss, Satin Stain, and Sparkle Lacquer.

**CUSTOM**  
Includes Pinstriping, Banding, Artisan II Custom Graphics.

**ARTISAN**  
Choose from a selection of Exotic veneers (below) or hand applied Carbonply.

**CUSTOM INLAY**  
Accentuate the natural beauty of the outer shell finish with inlay bands inserted by hand.



CAMEROON BLACK LIMBA

FLAME MAPLE

AFRICAN ZEBRA WOOD

TAMO ASH

BUBINGA

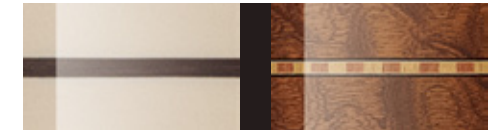

BARNWOOD

MOSAIC

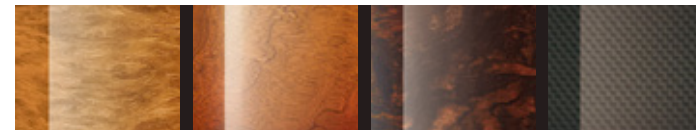

EUCALYPTUS

BURL MAHOGANY

IMBUIA

CARBONPLY

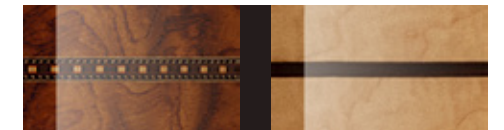

ROSETTE

EBONY

### BEARING EDGE

Masterworks offers a choice of five sonically tested edges - configurable by drum, application, and shell side.



**STANDARD 45°**  
Provides the perfect blend of attack and warmth.

**OUTER 60°**  
Pulls brighter overtones and increases punch.

**INNER 45°** Edge apex focused to inner shell plies for controlled sustain.

**ROUNDED 45°** Increased head-to-shell contact boosts mids and highs.

**FULLY ROUNDED**  
Boosts mid-to-low range response and reduces decay.

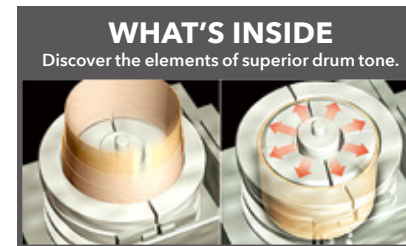

**THE EST DIFFERENCE - The Ultimate in Strength, Resonance, and Tone.**  
Superior Shell Technology

To craft multi-ply, bonded drum shells with single-ply resonance and strength, Pearl pioneered the world's first high temperature hydraulic curing system. SST shells are formed in a bonded combination of cross-laminated

2-ply veneer panels then precision milled with overlapping scarf joint seams and cured with our exclusive AcoustiGlue at 1000 PSI of hydraulic pressure.

### HARDWARE FINISH, LUG, AND HOOP OPTIONS

A choice of five plating options comes standard on your selection of our precision tuning lugs, hoops, and drum hardware.



**CHROME**  
(Shown w/ CL-100 Lug)

**NICKEL**  
(Shown w/ STL-100 Lug)

**BLACK NICKEL**  
(Shown w/ STL-150 Lug)

**GOLD**  
(Shown w/ STL-150 Lug)

**BLACK CHROME**  
(Shown w/ STL-100 Lug)

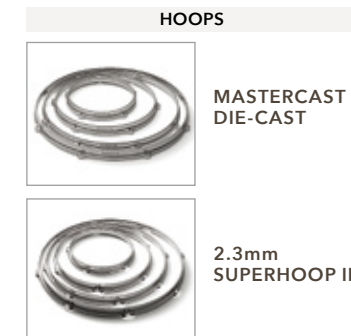

**MASTERCAST DIE-CAST**

**2.3mm SUPERHOOP II**



**FOR 12.7mm VERTICAL ROD**

**FOR 7/8" HORIZONTAL PIPE**

• Bridge (CL-100) • Single Swivel (STL-100) • Swivel Tube (STL-150)

# R2 AIR

SUSPENSION SYSTEM

TOTALLY BALANCED,  
TONALLY UNITED,  
FLOATING TOM SUSPENSION



## THE EVOLUTION OF TOM MOUNTING TAKES A GIANT LEAP FORWARD.

The physics of drum resonance is about to meet its match. For the first time, totally unrestricted, fully uninhibited, tonally uncolored sound can be drawn from mounted toms, with the Pearl R2 Air Tom Suspension system. U.S. Patent #11640814

Elevate the Physics - and Sound - of Your Drum. R2 Air improves the overall tone of the complete drum kit by delivering the true sound of each mounted tom by creating a transition bridge from toms to floor toms.

## ROCK SOLID, TOTALLY FLEXIBLE TOM POSITIONING.

Pearl is the first drum maker to offer a choice in tom mounting function. The GyroLock gearless positioning system offers the option of vertical placement with a 12.7mm solid L-arm, and the horizontal framing of our traditional 7/8" tube mount. Both offer infinite angle adjustment with a simple turn of the key without compromising sound or security. Unlike other L-arm holders that rely on a limited position, fallible ball-in-socket system, GyroLock's internal locking system can secure any angle without parts that wear over time.



**R2AL**  
FOR 12.7mm VERTICAL ROD



**R2AS**  
FOR 7/8" HORIZONTAL PIPE



MASTERWORKS SONIC-SELECT STUDIO RECIPE  
IN NATURAL FLAME MAPLE  
FEATURING  
R2 AIR / GYROLOCK-L COMBINATION

MASTERWORKS SONIC-SELECT STUDIO RECIPE  
IN NATURAL FLAME MAPLE  
FEATURING  
R2 AIR / GYROLOCK STANDARD  
PIPE COMBINATION

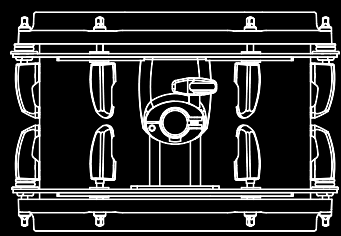

U.S. Patent #11640814

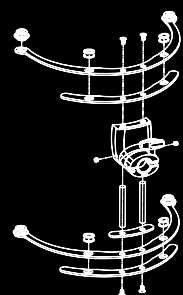

### EXCLUSIVE FOUR-POINT FLOATING ISOLATION PLATFORM.

To attain tonally true sound, every drum would have to be mounted in a floating point at the center of its shell. R2 Air equally balances mounting pressure across two floating points at the top and bottom of each tom. This gives true tonal separation from mounting hardware and enhances sonic output. All mounting hardware is isolated from the shell via the R2 Air's four ResoDisk shock absorption inserts.

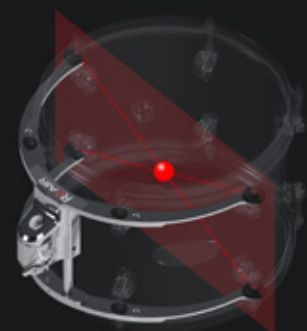

### DamperDisk

Sustain and tone can even be fine-tuned with the addition of its included rubber DamperDisk in one of four tension points. This shortens decay for a more pronounced note.



### MEMORY, WHERE YOU NEED IT MOST

GyroLock-L's position settings can be locked in place with the aid of additional memory locks in three separate places. This, plus our new Compass Dial markings, assure teardown and reset that is quick, secure, and repeatable. (Patent Pending)





## Sonic-Select Shell Recipes

# STUDIO

MASTERWORKS SONIC-SELECT STUDIO RECIPE SHELLS  
IN GLOSS RED/BLACK FADE WITH BLACK NICKEL HARDWARE  
AND ADDED TOP-TUNED DJEMBE (PBJV-14685)



### SONIC-SELECT SHELL RECIPES

#### CHOOSE YOUR ARENA. CREATE YOUR DREAM. DEFINE YOUR SOUND.

Our Sonic Select Shell Recipes narrow the nearly endless scope of Masterworks choice down to five sonically proven shell and hardware combinations. Each recipe is individually primed for its distinct performance environment.

#### STUDIO

Explosive tonal clarity and articulation for recording.

SHELL: EvenPly-Six (5.4mm) Maple/Gumwood w/ Outer 60° Bearing Edge

#### STADIUM

Pearl's thick CZX Maple shell for high-volume power.

SHELL: Fl.Toms/Bass: 10-ply Maple w/ Outer 60° Bearing Edges. Toms/Snares: 8-ply Maple w/ Outer 60° Bearing Edges

#### URBAN

A thin, powerful blend for the precise metropolitan drummer.

SHELL: Toms/Bass: EvenPly-Six Birch/Gumwood/Birch (5.4mm) with 4-ply Maple Re-Rings and mixed Bearing Edges

#### HERITAGE

Classic drum feel with enhanced lows and fat top-end slap.

SHELL: 4-ply Maple/Mahogany w/ 4-ply Maple Re-Rings w/ Standard 45° Bearing Edge

#### MODERN DRY

Quick, top-heavy articulation with controlled low-end.

SHELL: 4-ply Maple/Gumwood w/ 4-ply Mahogany Re-Rings w/ Inner 45° Bearing Edges

#### CUSTOMIZED TO FIT YOUR CREATIVE VISION.

Like a blank canvas for your drumming ideal, modify any Sonic-Select Shell Recipe shell or hardware option to give it your own spin or use our exclusive Artisan II process to embed your choice of high definition graphics directly onto the outer shell.

SEE [www.pearldrums.com/masterworks](http://www.pearldrums.com/masterworks)  
FOR FULL DETAILS

#### STUDIO

SHELL	EvenPly-Six (5.4mm), 4-ply Maple Outer with 2-ply Gumwood Inner
BEARING EDGE	Outer 60°
HOOPS	MasterCast Hoops
LUGS	CL Bridge Lug CL-100 (Toms) CL-250 (Bass Drum)
SPURS	SP-330
FT BRACKETS	LB-75

#### A POWERFUL SONIC FOUNDATION TUNED FOR THE RECORDING ENVIRONMENT.

This commanding shell/edge combination of hard exterior and milder tone woods yields explosive midrange projection and extended low end punch.



**SHELL**  
Thin, resonant combination of a hard exterior with milder tonewood for explosive low-range warmth.



**BEARING EDGE**  
Outer 60°  
Gives increased power and bite to a thinner hybrid shell.



**HOOPS**  
MasterCast Hoops. Escalates weight for tonal body. Increases volume in high velocity play.



**LUGS**  
CL Bridge Lug  
A classic look with minimal shell contact for precise vibration control.



Sonic-Select Shell Recipes

# STADIUM

# URBAN

A FRESH SONIC DRUM BLEND FOR THE METROPOLITAN PLAYER.

From sold out tours to sanctuary halls, the tonal dichotomy of three proven hardwoods projects with a defiant top end and fills the bass frequencies with thunderous, shaking lows.

## URBAN

SHELL	EvenPly-Six (5.4mm Toms/Bass)	HOOPS	2.3mm SuperHoop II*	
	2-Birch/2-Gumwood/2-Birch with		LUGS	STL Swivel Tube Lugs*
	4-ply Maple Re-Rings			STL150* (Toms)
	8-ply Snare Drums			STL300* (Bass Drum)
BEARING EDGE	2 Birch/4 Gumwood/2 Birch	SPURS	SP330	
	Rounded 45° on Toms	FT BRACKETS	LB75	
	Fully Rounded edge on Bass Drums Standard 45° on Snare Drums		* Recommended	



STADIUM	
SHELL	10-ply Maple BD & FT 8-ply Maple Toms and Snares
BEARING EDGE	Outer 60°
HOOPS	2.3mm SuperHoop II* CL Bridge Lug CL100 (Toms) CL250 (Bass Drum)
LUGS	CL100 (Toms) CL250 (Bass Drum)
SPURS	SP330
FT BRACKETS	LB75

\* Recommended

### THE CZX SOLUTION FOR HIGH VOLUME, RHYTHMIC COMMAND.

Pearl's legendary high density CZX Maple shell is reborn! Our classic 10-ply /8-ply shell combination delivers penetrating volume, articulate midrange attack, and focused low end.



MASTERWORKS SONIC-SELECT STADIUM RECIPE SHELLS IN SATIN NATURAL ARTISAN BURL MAHOGANY FINISH WITH MOSAIC INLAY AND GOLD HARDWARE

MASTERWORKS SONIC-SELECT URBAN RECIPE SHELLS IN VIVID BLUE OYSTER LACQUER WITH BLACK NICKEL HARDWARE



**SHELL**  
A thick shell for dominating volume and articulate attack.



**BEARING EDGE**  
Outer 60°  
Increases brightness and power with controlled overtone.



**HOOPS**  
2.3mm SuperHoop II Hoops - Made to withstand heavy play while allowing the shell to breathe.



**LUG**  
CL Bridge Lugs  
Heavier weight increases attack and assures the ultimate in tuning integrity.

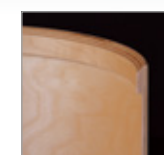

**SHELL**  
Dense, thin shell hybrid for precise punch and quick, even decay.



**BEARING EDGE**  
Rounded 45° on Toms (Fully Rounded edge on Bass Drums, Standard 45° on Snare Drums).



**HOOPS**  
2.3mm SuperHoop II Hoops - Made for heavy play without limiting tuning range performance.



**LUG**  
STL Swivel Tube Lug  
A medium-weight lug with pivoting tension casing for increased projection and reduced overtone.

# HERITAGE

# MODERN DRY



(Masterworks Heritage Kit not shown)

HERITAGE	
SHELL	Maple 2-ply outer Mahogany 2-ply inner w/ 4-ply Maple Re-Rings
BEARING EDGE	Standard 45°
HOOPS	2.3mm SuperHoop II Hoops*
LUGS	STL-100* (Toms) STL-200* (Bass Drum)
SPURS	SP-330
FT BRACKETS	LB-75

\*Recommended

### TIMELESS, ORGANIC TONE WITH SMOOTH LOW-END GROWL

The Heritage Recipe's robust blend of reinforced Maple/ Mahogany delivers solid midrange punch with exceptional sustain and thunderous sub bass frequencies.

MODERN DRY	
SHELL	2-ply Maple outer/2-ply Gumwood inner with 4 ply Mahogany Re-Rings
BEARING EDGE	Inner 45°
HOOPS	MasterCast Hoops*
LUGS	Single Swivel Lugs STL-100 (Toms) STL-200 (BD)
SPURS	SP-330
FT BRACKETS	LB-75

\*Recommended

### DARK NATURAL PUNCH FOR DRIVING, ORGANIC BEAT MAKING.

The Modern Dry Recipe blends three sonically unique tone woods for dark, controlled tone, and pillowy response. Its unique blend of shell and hardware elements adds bottom end focus and throaty punch.

MASTERWORKS SONIC-SELECT MODERN DRY RECIPE SHELLS WITH ADDED ROCKET TOMS IN #109 ARCTIC WHITE LACQUER FINISH



**SHELL**  
A traditional blend of midrange punch and boosted low-end.

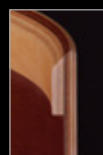

**BEARING EDGE**  
Standard 45°  
Precise, low-contact edge for added projection and resonance.



**HOOPS**  
2.3mm SuperHoop II Hoops - Made to withstand heavy play while allowing the shell to breathe.



**LUGS**  
CL Bridge Lugs  
Our lightest and most efficient tuning lug reduces hardware contact and weight on the shell.



**SHELL**  
A unique blend of yielding tone woods and rigid exterior for added bottom-end focus.



**BEARING EDGE**  
Inner 45°  
Its inner shell apex contacts the head inside the shoulder for focused control in low tunings.



**HOOPS**  
MasterCast Hoops  
Gives each drum added weight for increased volume and controlled sustain.



**LUGS**  
Single Swivel Lugs  
Our lightest and most efficient tuning lug for reduced shell contact.

# Reference — ONE —

The Reference Legacy.  
Unleashed.



## A TRUE PEARL ORIGINAL, WITH A FRESH, GROOVE INSPIRING VIBE.

Where the Many Combine to Create a Singular Instrument. Building on the modern hybrid drum concept Pearl originated with Reference Series, every element in the Reference One drum set's construction is fine-tuned to deliver optimal performance. By leveraging specific woods, shell thicknesses, and bearing edges exactly where they are most sonically beneficial within a drum set, Reference One's reduced-thickness EvenPly shells are fitted with MasterCast Die-Cast hoops, for a radical combination sustain and attack. Combined with Pearl's revolutionary R2 Air Tom Suspension System, Reference One takes the hybrid drum concept to new, unprecedented heights.



### R2 AIR TOM SUSPENSION SYSTEM

Suspends each drum by four unique points for optimum tone and resonance at any angle.



### MASTERCAST HOOP

Escalates weight for tonal body and increases volume in high velocity play.



### SWIVEL LUGS

Single Swivel Lugs are self-aligning for better tuning integrity and reduced shell stress. Their reduced profile takes up less room on the shell face, delivering better tone from each drum.



### GOLDEN RATIO AIR VENT

The Golden Ratio air vent location is unique for each component size to provide enhanced tonal character and frequency response. (U.S. Patent # 7485791)

RF1C924XESPL/C  
#885 Cherry Amber Fade









RF1C924XSPS/C +  
14x14 Floor Tom  
#393 Purple Craze II

SHELL	Refer to Size / Shell Chart
SNARE	Matching 13x6.5, 14x5, 14x6.5, 14x8
FINISH	CHOICE of over 50 finishes of Hand-Applied Premium or Custom Lacquer Finishes
HEADS	Remo Coated Ambassador, Powerstroke3 Bass
TOM MOUNTS	R2 Air Tom Suspension system (U.S. Patent #11640814)
TOM ARMS	CHOICE of Pearl's Traditional 7/8" Pipe Holder or 12.7mm Solid L-Arm (Sold Separately)
DRUM HARDWARE	Chrome (Standard) Black nickel, Nickel and Black Chrome (Premium Charge)
HOOPS	Mastercast Hoops
LUGS	STL Single Swivel Lugs
BD MUFFLER	BDM-F

### SHELLS

Each drum has its own custom shell, edge, and thickness profile to best suit its place in the drum set.



REFERENCE RECIPE	SHELL TYPE	BEARING EDGE	SONIC OUTPUT
8" and 10" Toms	 <b>Maple(4)/Birch(2)</b> 6-ply (5.4mm)	Rounded 45°	Cutting projection for high-note pitch
12" Toms	 <b>Maple(6)</b> 6-ply (5.4mm)	Rounded 45°	Transitional mid-note; blend of warmth and cut
13" Toms	 <b>Maple(4)/Mahogany(2)</b> 6-ply (5.4 mm)	Rounded 45°	Top-end slap with added low/bottom end
14" and 15" Toms	 <b>Maple(4)/Mahogany(2)</b> 6-ply (5.4 mm)	Fully Rounded	Bracing low-end with controlled punch
16" Toms	 <b>Maple(2)/Mahogany(4)</b> 6-ply (5.4mm)	Fully Rounded	Full, rounded sustain and gated attack
14" Floor Toms	 <b>Maple(4)/Mahogany(4)</b> 8-ply (7.2mm)	Fully Rounded	Fat, controlled low-end with smooth roll-off
16" and 18" Floor Toms	 <b>Maple(2)/Mahogany(6)</b> 8-ply (7.2mm)	Fully Rounded	Fat, controlled low-end with resonant warmth
18" and 20" Bass Drums	 <b>Maple(2)/Mahogany(4)</b> 6-ply (5.4mm)	Fully Rounded	Quick and Punchy with Powerful low-end
22" and 24" Bass Drums	 <b>Maple(2)/Mahogany(6)</b> 8-ply (7.2mm)	Fully Rounded	Booming bass tone with articulate punch



# Masters

The Masters You Remember,  
A Sound You'll Never Forget

## ELEVATING THE PLAYING EXPERIENCE FOR THE TRUE PROFESSIONAL.

Pearl's Masters Series has set a standard for the very best in performance centered instruments for the pro drummer. In celebration of three decades of Masters quality and excellence, Pearl reimagines three original shell recipes with a freshly unified hardware mix to reach new levels of sonic purity the most discerning environments and players.

## MASTERS SHELL CHOICES



**MASTERS MAPLE/GUM (MMG)**  
Masters Maple/Gum (MMG) Primed for the Recording Studio, this legendary shell blend enhances the naturally vibrant sonic nature of Maple with explosive highs and lows.



**MASTERS MAPLE (MM6)**  
Originally offered as Masters MRX, projects powerfully expressive tone fit for evolving live music environments. Sonically centered with equal Highs/Mids/Lows.



**MASTERS MAPLE PURE (MP4)**  
The Original Masters Sound delivers full bodied resonant tone with increased lows and a more focused attack.

## MASTERS HARDWARE SELECTION

Adding the groundbreaking R2 Air Tom Suspension system's four point mounting platform to Pearl standards like premium North American shell veneers and Mastercast Die-Cast Hoops, Masters Series is the defining essence of the Pearl Sound and tailored to fit your sonic vision.



**R2 AIR TOM MOUNTS**  
Suspends each drum by four unique points for optimum tone and resonance at any angle. (L-Arm bracket shown) U.S. Patent #11640814



**PEARL STANDARD 7/8" PIPE OR 12.7mm L-ARM BRACKETS**  
A choice of Vertical or Horizontal Mounting and flexibility. (Standard bracket shown) U.S. Patent Pending



**MASTERCAST HOOPS**  
The ultimate choice for durability and tuning integrity, they increase overall shell weight for enhanced tonal body and volume.



**CL BRIDGE LUGS**  
A classic look with minimal shell contact for precise vibration control.



**MASTERS MAPLE GUM KIT (MMGP924XSPL/C)** IN #844 SATIN ROSE GOLD LACQUER FINISH ON CONFIGURED ICON RACK SYSTEM WITH ADDED 8"x7" AND 13"x9" TOMS AND 14"x14" FLOOR TOM

# Masters

MAPLE/GUM  
HANDCRAFTED SHELL

The Evolution of  
Premium Studio Tone



## THE MASTERWORKS STUDIO RECIPE, SIMPLIFIED.

Delivering arguably the greatest drum tones ever recorded, Pearl's performance-centered take on the legendary Maple/Gum shell recipe is a sonic experience every drummer needs to witness. Reaching epic levels in sonic warmth and explosive low-end response, this dynamic shell/hardware combination first debuted as the Masterworks Sonic Select Studio Recipe. With the addition of the R2 Air Tom Suspension System, this is an instrument that is perfectly at home in the Recording environment, and a true prize for each drummer that owns one.



**OUTER 60° BEARING EDGE**  
Gives increased power and bite to a thinner hybrid shell.



**R2 AIR TOM SUSPENSION SYSTEM**  
Suspends each drum by four unique points for optimum tone and resonance at any angle. (U.S. Patent #11640814)



**MASTERCAST HOOPS**  
The ultimate choice for durability and tuning integrity, they increase overall shell weight for enhanced tonal body and volume.



**CL BRIDGE LUGS**  
A classic look with minimal shell contact for precise vibration control.



MMGC924XESPS/C + 14x14 Floor Tom  
#857 Sunburst Redstripe



MMGC903XPL/C + 16x16 Floor Tom  
#195 Crystal Rain

### MASTERS SHELLS

Only the finest cuts of North American hardwood are harvested for Pearl's Masterworks Shell Vault. Cross laminated into dual-layered panels, each veneer in the Masters shell has been hand selected from this exclusive cache to produce drums worthy of Pearl's commitment to quality and performance.

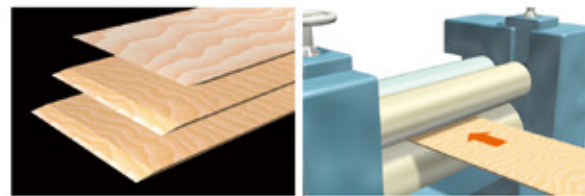

### SUPERIOR SHELL TECHNOLOGY

The SST method was developed to craft a multi-ply, bonded drumshell with single-ply resonance and strength. All shells are precision milled with overlapping scarf joint seams and cured with our exclusive AcoustiGlue at 1000 PSI of hydraulic pressure.

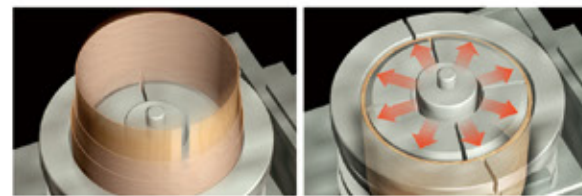

### SHELLS

EvenPly-Six, 4-ply Maple outer with 2-ply Gumwood inside – The natural warmth of Maple is enhanced by Gumwood's dense, controlling character.



SHELL	EvenPly-Six (6-ply, 5.4mm) North American Maple / Gumwood
SNARE	Matching 13x6.5, 14x5, 14x6.5, 14x8
FINISH	CHOICE of over 50 finishes of Hand-Applied Premium or Custom Lacquer Finishes
HEADS	Remo USA Coated Ambassador, Powerstroke3 Bass
TOM MOUNTS	R2 Air Tom Suspension System (U.S. Patent #11640814)
TOM ARMS	CHOICE of Pearl's Traditional 7/8" Pipe Holder or 12.7mm Solid L-Arm (Sold Separately)
DRUM HARDWARE	Chrome (Standard) Black nickel, Nickel and Black Chrome (Premium Charge)
HOOPS	Mastercast Hoops
LUGS	CL Bridge Lugs
BD MUFFLER	BDM-F

# Masters

MAPLE  
ALL MAPLE SHELL

Sonically Centered,  
Articulate, and Powerful.



## A BOLD VOICE FOR HIGH VOLUME STAGE PROJECTION.

With a sound that sits in the tonal center of the mix, Masters Maple is Pearl's original 6-ply shell recipe. This timeless combination of a slightly thicker 6-ply North American Maple shell and a sharper 45-degree bearing edge produces enough precise projection to shake the rafters, yet is responsive to even the slightest stroke. With an equalized high/mid/low tonality, Masters Maple is primed for cutting, vibrant live performance.



### STANDARD 45° BEARING EDGE

Pearl's original precision edge adds sustain through reduced shell-to-head contact.



### R2 AIR TOM SUSPENSION SYSTEM

Suspends each drum by four unique points for optimum tone and resonance at any angle. (U.S. Patent #11640814)



### MASTERCAST HOOPS

The ultimate choice for durability and tuning integrity, they increase overall shell weight for enhanced tonal body and volume.



### CL BRIDGE LUGS

A classic look with minimal shell contact for precise vibration control.



**MM6C924XESPS/C + 14x14 Floor Tom**  
#198 Shimmer Of Oz

**MM6P924XESPS/C + 14x14 Floor Tom**  
#103 Piano Black

### MASTERS SHELL HARDWARE

Die-Cast for solid stability in the most demanding conditions, the appointments on each Masters shell were designed to draw the best tone from the shell they support. Mastercast Hoops, low mass CL Bridge Lugs, a choice of mounting options with the R2 Air Tom Suspension System, and refreshed adjustable Bass Drum Spurs and Floor Tom Brackets are standard.



### USA REMO DRUM HEADS

All Pearl Masters come with REMO USA Drum Heads. Toms feature Coated Ambassador Batters with Clear Ambassador Resonant heads. Bass Drums are furnished with Powerstroke 3 Batter and Resonant heads, and come with our exclusive adjustable Dampening Pillow (BDM-F).



### SHELLS

6-ply, 7.5mm hand-selected North American Maple with Veneers from Pearl's Masterworks Vault.



SHELL	6-Ply, 7.5mm North American Maple
SNARE	Matching 13x6.5, 14x5, 14x6.5, 14x8
FINISH	CHOICE of over 50 finishes of Hand-Applied Premium or Custom Lacquer Finishes
HEADS	Remo USA Coated Ambassador, Powerstroke3 Bass
TOM MOUNTS	R2 Air Tom Suspension System (U.S. Patent #11640814)
TOM ARMS	CHOICE of Pearl's Traditional 7/8" Pipe Holder or 12.7mm Solid L-Arm (Sold Separately)
DRUM HARDWARE	Chrome (Standard) Black nickel, Nickel and Black Chrome (Premium Charge)
HOOPS	Mastercast Hoops
LUGS	CL Bridge Lugs
BD MUFFLER	BDM-F

# Masters

MAPLE PURE  
ALL MAPLE SHELL

Bridging the Gap Between  
Studio and Stage.



## A POWERFUL TONAL BLEND OF RESONANCE AND ATTACK.

Pearl reimagines the original Masters shell recipe with Masters Maple Pure. Blending four layers of hand-curated North American Maple with 4-ply Re-Rings from our Masterworks Veneer Vault, its premium shell formula delivers a sonic fusion of near-field resonance and sharp top-end attack for varied pro environments. These hand-curated Maple plies increase the overall Janka hardness of the shell for increased projection, improved sustain, and better sonic output than ever before.



### STANDARD 45° BEARING EDGE

Pearl's original precision edge adds sustain through reduced shell-to-head contact.



### R2 AIR TOM SUSPENSION SYSTEM

Suspends each drum by four unique points for optimum tone and resonance at any angle. (U.S. Patent #11640814)



### MASTERCAST HOOPS

The ultimate choice for durability and tuning integrity, they increase overall shell weight for enhanced tonal body and volume.



### CL BRIDGE LUGS

A classic look with minimal shell contact for precise vibration control.



MP4C924XESPL/C +  
14x14 Floor Tom  
#855 Black Oyster Swirl

MP4P924XSPL/C  
#102 Natural Maple

### MASTERS SELECTION

Pearl is committed to offering each drummer a top-tier experience in selecting and purchasing their Masters Series kit. Available for immediate delivery in a curated variety of in-stock components, Masters gives you the freedom of configuring your ideal set-up without the restriction of pre-formatted shell packs.



### MASTERS FINISHES

Available in a wide range of Premium and Custom exterior lacquers, Masters drum finishes are hand-applied through Pearl's painstaking thirty-one step process. Choose from over 50 different Transparent, Metallic, Fade, Burst, Sparkle, Swirl, or Stripe Lacquers for your own unique statement.



### SHELLS

5mm 4-ply shell w/4-ply Re-Rings blends hand-selected North American Maple Veneers from Pearl's Masterworks Vault.



SHELL	4-Ply, 5mm Maple w/4-ply Reinforcement Rings
SNARE	Matching 13x6.5, 14x5, 14x6.5, 14x8
FINISH	CHOICE of over 50 finishes of Hand-Applied Premium or Custom Lacquer Finishes
HEADS	Remo Coated Ambassador, Powerstroke3 Bass
TOM MOUNTS	R2 Air Tom Suspension System (U.S. Patent #11640814)
TOM ARMS	CHOICE of Pearl's Traditional 7/8" Pipe Holder or 12.7mm Solid L-Arm (Sold Separately)
DRUM HARDWARE	Chrome (Standard) Black nickel, Nickel and Black Chrome (Premium Charge)
HOOPS	Mastercast Hoops
LUGS	CL Bridge Lugs
BD MUFFLER	BDM-F

# PROFESSIONAL SERIES

ALL MAPLE SHELL

Est. 1986. An Updated,  
Upgraded, Premium Gigging  
Powerhouse.



## A PLAYER-READY DRUM SET PLATFORM FIT FOR ACTIVE GIGGING AND TOURING..

From local gigs to national tours, Pearl's updated Professional Series drums have a look and sound that fits in any live performance space. Beginning in 1985, Pearl introduced its legendary MLX drums under the Professional Series banner to bring the powerful Maple sound to the forefront. Today, Professional Series returns with the spirit of the original and a refreshed presence for the experienced drummer.



### STANDARD 45° BEARING EDGE

Pearl's original precision edge adds sustain through reduced shell-to-head contact.



### OPTIMOUNT SUSPENSION SYSTEM

A solid, flexible four point suspension mount for prime shell resonance.



### 2.3mm SuperHoop II

Made to maintain tuning integrity in heavy play while delivering maximum shell resonance.



### RL LUGS

A simple, sleek lug that adds weight to the shell for increased volume.



**PMX924BEDP/C**  
#448 White Marine Pearl

**PMX943XP/C + 18x16 Floor Tom**  
#113 Sheer Blue

### PERFORMANCE PROVEN

Made for lively sonic warmth from the cockpit, Professional Series drums broadcast with a broad frequency spectrum on and off the gig. A host of transparent Gloss Lacquer (and one Premium wrap) finishes assure a solid look and feel in varied venues and climates.



### HARDWARE

Our classic RL Lug, OptiMount Tom Suspension System, 2.3mm Superhoop II, and Remo UT Pinstripe heads are added for strength and stability. Finally, to save your stand footprint and cartage load, Pearl's original UniLock independent bass drum mounted tom holders deliver maximum adjustability and positioning without robbing the shells of tone or sustain.



### SHELLS

EvenPly-Six (5.4mm) North American Maple - Fuses reduced thickness, cross laminated ply panels for expanded tonal purity and increased resonance.



SHELL	EvenPly-Six (5.4mm) North American Maple
SNARE	Matching 14 x 5, 14 x 6.5, 14 x 8
FINISH	Premium Transparent Lacquer and USA Covered Finishes.
HEADS	Remo UT Pinstripe Batter Heads.
TOM MOUNTS	OptiMount Suspension System.
TOM ARMS	TH-1030I x2 (with BB only)
DRUM HARDWARE	Chrome
HOOPS	2.3mm Triple-Flanged SuperHoop II Hoops
LUGS	RL Lugs
BD MUFFLER	BDM-M

# SESSION STUDIO SELECT

A Completely New Take  
on the Full Spectrum Sound



**A TRUE PEARL ORIGINAL, WITH A FRESH, GROOVE INSPIRING VIBE.**

Taking a tip from the Masterworks spectrum, Session Studio Select's unparalleled combination of Masters-grade Birch and African Mahogany deliver a refined standout for recording and gigging.

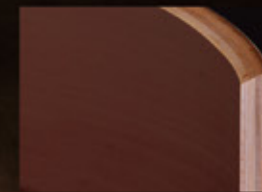

**OUTER 60° BEARING EDGE**  
Increases volume and punch without harsh overtones.



**OPTIMOUNT SUSPENSION SYSTEM**  
A solid, flexible four point suspension mount for prime shell resonance.



**2.3mm SuperHoop II**  
Made to maintain tuning integrity in heavy play while delivering maximum shell resonance.



**RL LUGS**  
A simple, sleek lug that adds weight to the shell for increased volume.



**STS925XSP/C**  
#852 Black Satin Ash

**STS925XSP/C**  
#314 Gloss Barnwood Brown

**HARDWARE PARTS**

Our classic RL Lug, OptiMount Tom Suspension System, 2.3mm Superhoop II hoops, and Remo UT Pinstripe heads are added for strength and stability.

<b>SHELL</b>	EvenPly-Six (6-ply, 5.4mm) Birch/African Mahogany
<b>SNARE</b>	14 x 5.5, 14 x 6.5, or 14 x 8 Matching Wood
<b>FINISH</b>	Premium Wrapped or High Gloss Lacquer
<b>HEADS</b>	Remo Pinstripe Clear Tom, Powerstroke3 Bass, UT Coated Snare
<b>TOM MOUNTS</b>	OptiMount Suspension System
<b>TOM ARMS</b>	Sold Separately
<b>DRUM HARDWARE</b>	Chrome
<b>HOOPS</b>	2.3mm Triple-Flanged SuperHoop II Hoops
<b>LUGS</b>	RL Lugs
<b>BD MUFLER</b>	BDM-M

**SHELLS**

EvenPly-Six Birch/African Mahogany. An unique sonic dichotomy of piercing projection, smooth low-end and pre-EQ'd punch.



# PRESIDENT

A Modern Revival of The Darkly Unique Luan Sound



## DELIVERING A DISTINCTLY CLASSIC PLAYER'S GROOVE.

Drawing from the very origins of Pearl's manufacturing legacy, President Deluxe Series showcase the warm subtlety of our original tone wood for a traditionally full, controlled playing experience. Featuring our original 6-ply Luan shell, this darker toned medium/hardwood was the basis of thousands of shells made by Mitsuo Yanagisawa in Pearl's Chiba, Japan-based drum factory starting in 1961.



### ROUNDED 45° BEARING EDGE

Increased head-to-shell contact boosts mids and highs and helps control overtone spread.



### 2.3mm SuperHoop II

Made to maintain tuning integrity in heavy play while delivering maximum shell resonance.



### BSL LUGS

"The Battleship Lug", BSL-100 features the same striking design of the original "C-043" lug in a more robust casting for better tuning integrity.



### SHELLS

6-ply 7.5mm Luan. Loud yet subdued with deep, punchy wallop and plenty of top-end attack.

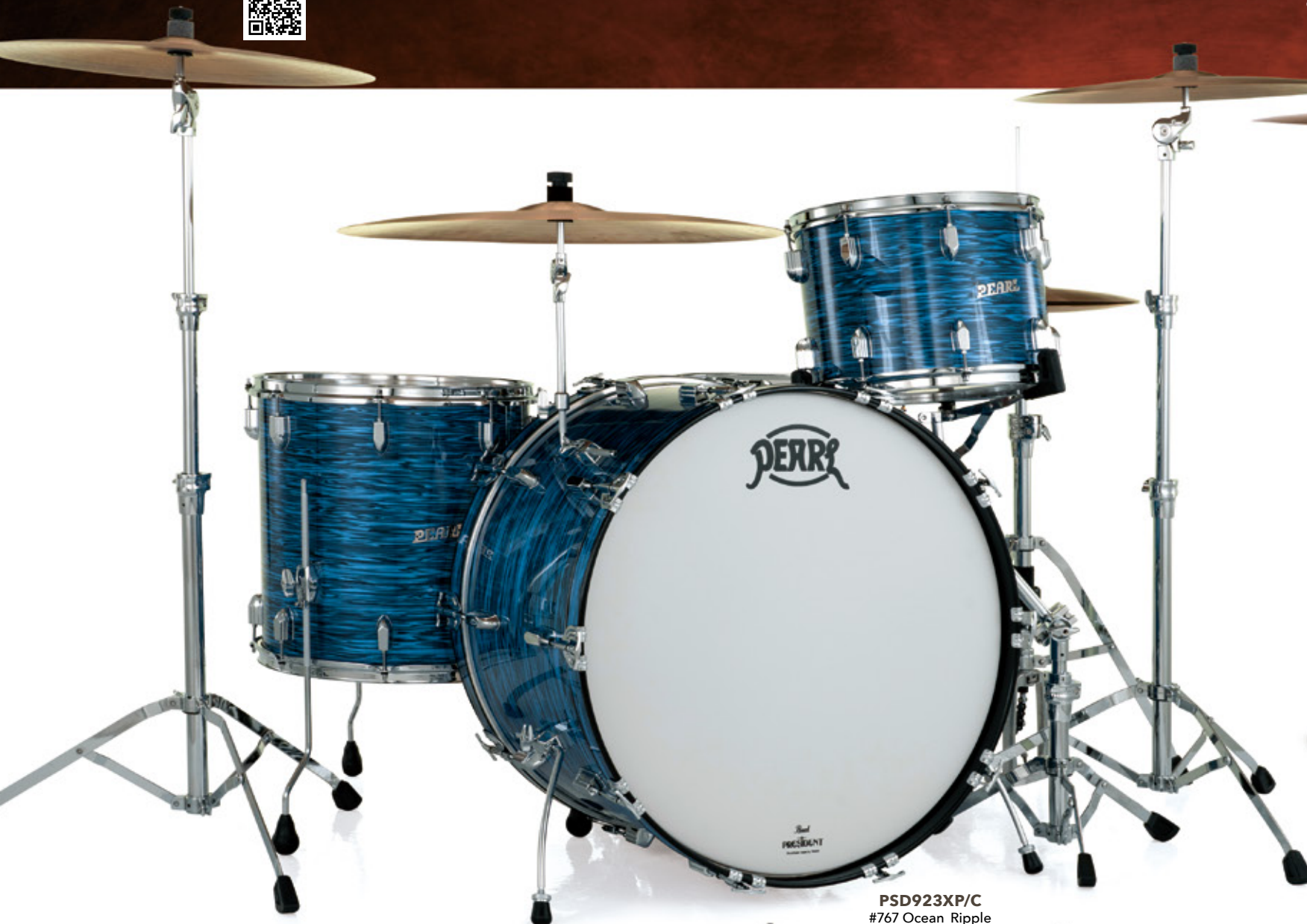

PSD923XP/C  
#767 Ocean Ripple



PSD923XP/C  
#769 Sunset Ripple

## A MODERN TAKE ON A FAMILIAR FAVORITE

President Series Deluxe drums feature prime vintage style without the shortcomings of yesterday's fittings. Available in three shell packs with a host of component add-ons, each President Series Deluxe drum kit comes standard with Remo CS "Black Dot" UT heads, classic felt bass drum muffling strip, shell-mounted cymbal holder, and adjustable "Gullwing" style bass drum spurs.



## SINGLE-HEADED CONCERT TOM SET

A period-correct companion to President Series Deluxe shell packs. Includes 8"x6" and 10"x7" single headed toms with Traditional Slide/Clip mounts.



SHELL	6-ply 7.5mm Luan
SNARE	14" x 5.5" * Sold Separately
FINISH	Premium USA Wraps
HEADS	Remo UT CS Black Dot Batters Smooth White Coated Ambassador w/ Classic Pearl Logo
SPURS	BSP-835 "Gullwing" Style
BD CYMBAL MOUNT	CHB-75LB
HOOPS	2.3mm Triple-Flanged SuperHoop II Hoops
LUGS	Battleship Lugs (BSL-100 (Toms), BSL-200 (Bass Drum))
BD MUFFLER	BDM-F and Resonant Felt Strip

# CRYSTAL BEAT

50 Years of the Original  
Seamless Acrylic Drum Shell



## THE ORIGINAL SEAMLESS ACRYLIC DRUM SET

Beginning in 1973, Pearl established a revolutionary alternative to conventional drum making with Crystal Beat's 6mm/7mm molded/seamless Acrylic shell. Its vivid combination of cutting tonal power and stunning visual appeal found an immediate audience with the high-volume power player. In celebration of this 50 year milestone, Pearl introduces three never before released acrylic finishes in a Limited Edition selection of Crystal Beat shell packs. Released quarterly throughout the year in Small Batch production runs, each shell pack is built to stand up to the rigors of touring with an undeniably unique look and straight-tone power.



### STANDARD 45° BEARING EDGE

Pearl's original precision edge adds sustain through reduced shell-to-head contact.



### OPTIMOUNT TOM SUSPENSION SYSTEM

A solid, flexible four point suspension mount for prime shell resonance.



### 1.6mm STEEL HOOPS

Solid tuning performance with reduced weight.



### CRBL LUGS

Each sleek and efficient lug is individually isolated from shell contact with nylon gaskets to prevent hardware rattle in play.

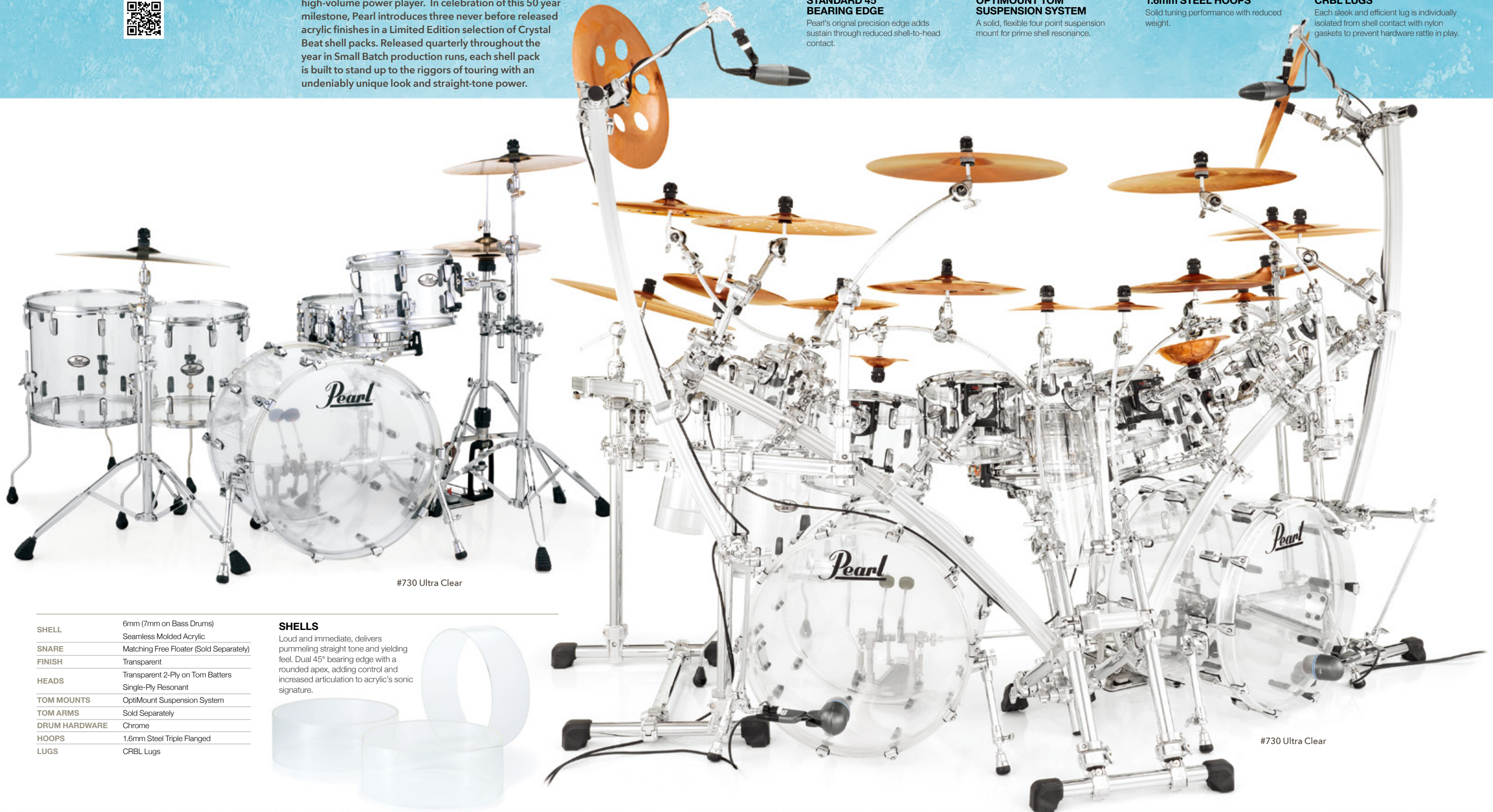

#730 Ultra Clear

#730 Ultra Clear

SHELL	6mm (7mm on Bass Drums) Seamless Molded Acrylic
SNARE	Matching Free Floater (Sold Separately)
FINISH	Transparent
HEADS	Transparent 2-Ply on Tom Batters Single-Ply Resonant
TOM MOUNTS	OptiMount Suspension System
TOM ARMS	Sold Separately
DRUM HARDWARE	Chrome
HOOPS	1.6mm Steel Triple Flanged
LUGS	CRBL Lugs

### SHELLS

Loud and immediate, delivers pummeling straight tone and yielding feel. Dual 45° bearing edge with a rounded apex, adding control and increased articulation to acrylic's sonic signature.

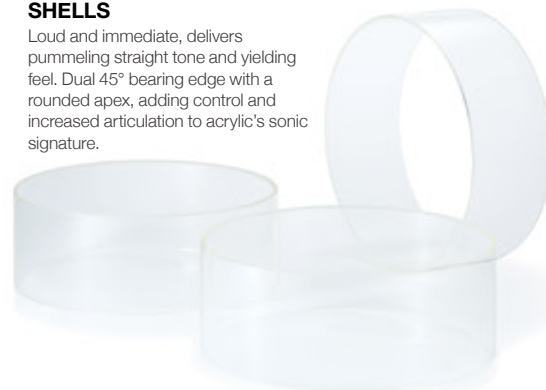



# DECADE MAPLE

A Drum Kit  
10 Years in the Making



## BUILT TO PUSH THE BOUNDARIES OF PERFORMANCE AND PRICE

Decade Maple Series drums elevate the playing field for the advancing drummer with pro features and unbeatable value. Over seven decades of Pearl drum craftsmanship and ten full years of research and development culminate in the ideal step up drum kit: Decade Maple Series. Escalating the playing field for the advancing drummer, Decade Maple's featured shell packs are perfect as a primary kit for evolving players or a secondary "gigging" kit for the seasoned pro.



### STANDARD 45° BEARING EDGE

Pearl's original precision edge adds sustain through reduced shell-to-head contact.



### OPTI-LOC MOUNTING SYSTEM

This three-point isolation mount suspends the drum at two tuning points and one of the drum's air vents for solid, stable play.



### 1.6mm STEEL HOOPS

Solid tuning performance with reduced weight.



### NDL LUGS

Small, efficient, and strong, the ND L lug is designed to hold tuning across all points without taking up too much room on the shell.



**DMP943XP/C**  
#849 Rose Mirage

**DMP925SP/C**  
#208 Blue Mirage

### BDM-M BASS DRUM MUFFLER

Brings out the PUNCH in your kick.



### HARDWARE

- Uni-Lock gearless Tom Arms.
- R-40 Air Suspension Floor Tom feet.
- ND L Lugs: For reliable, rock solid durability and sound.



### SHELLS

EvenPly-Six (5.4mm) Maple - Thin (but powerfully strong) Pearl's SST shell reacts quickly to the stroke with beautifully resonant highs and thundering lows.



SHELL	EvenPly-Six (5.4mm) 100% Maple
SNARE	Matching 14 x 5.5
FINISH	High-Gloss / Matte Lacquer
HEADS	Remo UT Clear Ambassador Tom, Ported UT Powerstroke3 Bass
TOM MOUNTS	Opti-Loc Mounting System
DRUM HARDWARE	Chrome
HOOPS	1.6mm Steel Hoops
LUGS	NDL Lugs
BD MUFFLER	BDM-M (Mini)



The Legends of Tomorrow,  
Play Export Today



**THE BEST SELLING DRUM SET OF ALL TIME.**

**THE BEST SELLING DRUM SET OF ALL TIME**

The Export Series 30 year pedigree of unbeatable quality and value shines on with Reference-inspired shell woods and high impact hardware, giving the rising player a truly high end playing platform.

Export Series drums are available in three preconfigured packages with our robust 830 Series hardware; and feature a choice of durable wrapped (EXX) finishes. Pearl carries this tradition forward with our best Export ever - fully loaded with all the features to advance your playing voice to new heights. Never settle. Play Export.



**STANDARD 45° BEARING EDGE**

Pearl's original precision edge adds sustain through reduced shell-to-head contact.



**OPTI-LOC MOUNTING SYSTEM**

This three-point isolation mount suspends the drum at two tuning points and one of the drum's air vents for solid, stable play.



**1.6mm STEEL HOOPS**

Solid tuning performance with reduced weight.



**NEL LUGS**

Small and elegant for reduced real estate on the shell, but efficient enough for tuning integrity in play.



**EXX705N/C**  
#21 Smokey Chrome



**EXX7255/C, EXX22 Add-On Pack.**  
#31 Jet Black

SHELL	6-Ply 7.5mm Poplar & Asian Mahogany Blend
SNARE	14 x 5.5 Matching Wood Snare
FINISH	Choice of 8 Covered Finishes
HEADS	Remo Clear Tom Head, Powerstroke Bass Head
TOM MOUNTS	Opti-Loc Mounting System
TOM ARMS	TH-70I
DRUM HARDWARE	Chrome
HARDWARE	P-930, BC-830, C-830, H-830, S-830
BD MUFLER	BDM-M (Mini)



**830 SERIES HARDWARE**

Sophisticated, sturdy, and efficient, Export's 830 Series Boom (BC-830), Cymbal (C-830), and Snare (S-830) stands all feature gearless Uni-Lock Tilters for pinpoint positioning, and robust double-braced tripods for stability and security.

**P-930 PEDAL**

Featuring the longboard styling and feel of Pearl's Demon Drive pedal, the P-930 offers two chain drive cam options for power, speed, and control. The matching H-830 Hi-Hat stand also features swivel legs that accommodate double pedals.



**SHELLS**

6-Ply 7.5mm Poplar & Asian Mahogany Blend (but powerfully strong) Pearl's SST shell reacts quickly to the stroke with beautifully resonant highs and thundering lows.

# MIDTOWN

BIG GIG, SMALL RIG, HUGE SOUND



MDT764/C  
#701 Black Gold Sparkle

## SHELLS

6-Ply (7.5 mm) Poplar. Quick and biting attack with lively overtones.



## FINISHES



#33 Pure White

#701 Black Gold Sparkle

#704 Black Cherry Glitter

## HARDWARE

Lift used on Midtown raises the drum to the optimal position for your pedal.



## CONFIGURATIONS

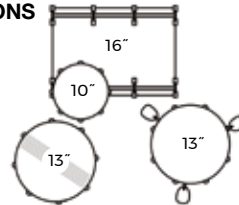

## INSTANTLY PORTABLE

The Midtown Kit's compact size quickly breaks down into two optional gig bags (PMTBG) for quick transport.

## SETTING THE PULSE FOR THE METROPOLITAN GROOVE

Pearl's ultra portable Midtown Kit is the perfect sounding board for full size sound and play in a smaller footprint. Ideal for tight gigging spaces on a budget.

SHELL	6-Ply (7.5 mm) Poplar
SNARE	Matching 13x5.5 Wood Snare Drum
FINISH	Choice of 3 Covered Finishes
HEADS	Remo UC Clear Tom Remo UC Clear Powerstroke Batter Bass Remo UC Coated Snare
TOM ARMS	TH-701
HARDWARE	Chrome

# ROADSHOW

IT'S YOUR TIME TO PLAY, START THE RIGHT WAY!

## THE RHYTHM IS IN YOU

Drumming knows no age limit. Regardless of when your rhythmic journey starts, Pearl's Roadshow Series has a drum set package scaled for players of all ages that includes everything you need to get on the road to drumming greatness.



RS525SC/C  
#749 Burnt Orange Sparkle

SHELL	9-Ply 7mm Asian White Poplar
SNARE	Matching Wood Snare
FINISH	Choice of 8 Covered Finishes
HEADS	Clear Tom Heads, Coated Snare Head, Self-Muffled Bass Head
TOM ARMS	Individually Locking 7/8" Tube Joint Holders
HARDWARE	Dual-Chain Drive Bass Drum Pedal Double-Braced Cymbal*, Snare and Hi-Hat Stands, Double-Braced Throne
CYMBALS	16" Brass Cymbal, 14" Brass/ Hybrid Hi-Hat Cymbals
ACCESSORIES	Pro Drum Stick Bag, Two pairs of Maple 5A Sticks

\*Docking Cymbal Boom Arm Included with RS584C/C

## CONFIGURATIONS

Complete Sets with Hardware, Cymbals, and Throne. Includes CH-50/H-50/S-50\*/P-50/D-50/16" Crash/14" Hi-Hats, Stick Bag, Sticks

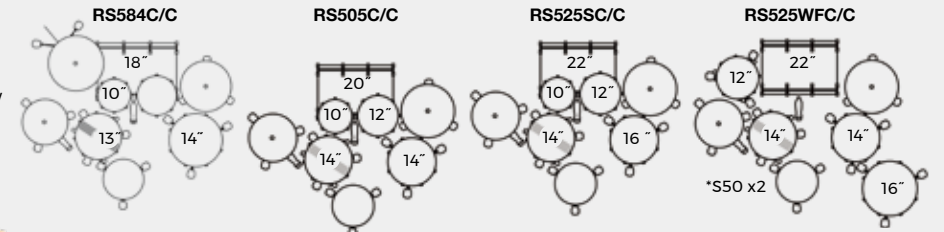

RS584C/C  
#706 Charcoal Metallic

## THE HEART OF THE ROADSHOW SOUND.

Roadshow is crafted to be everything you'd expect from a Pearl Drum set, featuring a 9-ply Poplar shell for optimum tonal power.



#31 Jet Black

#33 Pure White



#91 Red Wine

#703 Aqua Blue Glitter

#706 Charcoal Metallic

#707 Bronze Metallic

#743 Royal Blue Metallic

#749 Burnt Orange Sparkle

# ROCKET TOMS

For striking staccato tone that's both melodic and piercing, Pearl's Rocket Toms are 6" pitched toms in varying lengths made to expand the sonic palette of any drum kit.

Available in sets or as individual components in Aluminum. Finishes: #103 Piano Black, #109 Arctic White, or #730 Ultra Clear Acrylic.



AL-0612/C	6" x 12"
AL-0615/C	6" x 15"
AL-0618/C	6" x 18"
AL-0621/C	6" x 21"
ALX-1215/C	6" x 12", 6" x 15" (w/ T890)
ALX-1821/C	6" x 18", 6" x 21" (w/ T890)
CRB612/C	6" x 12" (Acrylic #730 Ultra Clear)
CRB615/C	6" x 15" (Acrylic #730 Ultra Clear)
CRB618/C	6" x 18" (Acrylic #730 Ultra Clear)
CRB621/C	6" x 21" (Acrylic #730 Ultra Clear)

# COMPACT TRAVELER

BASS DRUM	18" w/ Base Frame & L-Arm Handle
SNARE	10" w/ Adjustable Snare Rake
STANDS	Sold Separately
CARRYING CASE	PSC-PCTK (Sold Separately)
ADD ON PACK	PCTK-1014 Includes 10" & 14" Toms w/ Mounting Hardware

Take the rhythm on the road with Pearl's totally portable, super playable, ultra affordable beat maker. Perfect for School, Street, Practice, and Stage.



Shown with PCTKT1014 add on pack\* PCTK-1810



Pedal sold separately PCTK-1810

Add on pack (10" & 14" toms w/ mounting hardware) PCTKT-1014

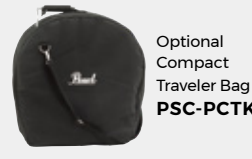

Optional Compact Traveler Bag PSC-PCTK



Optional Compact Traveler Add on Bag PSC-PCTKADD

# ROADSHOW JR.

Pearl's Roadshow Jr. is NOT a toy. It's a serious, all-in-one, five piece drum set sized for kids under 8-years-old featuring hardware, cymbals, and sturdy White Poplar shell construction for an exceptionally powerful drumming start.

Complete with Hardware, Cymbals, and Throne for Drummers under 8.

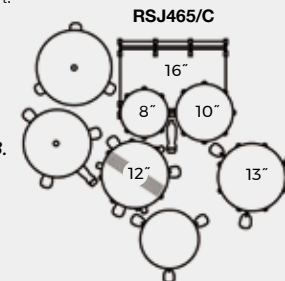

RSJ465/C



For additional info, testimonials, free assembly and instructional videos, and access to the largest drummer's community on the web, go to:



# SERIES COMPONENT

Reference One, Masters MMG Series

Masters Maple, Masters Maple Pure, Professional Series

## Reference One

A nuanced, refined balance of sensitive response and sonic versatility, Reference One Series Snare Drums are an exceptional complement to the total sound of any drum set. Combining an EvenPly blend of hand-curved North American Maple and Birch, the 5.4mm Reference One shell delivers a smooth, resonant quality with heightened top-end pop at the hit. Each snare's hardware selection includes elements that balance overall weight from top to bottom, for supreme sensitivity and crisp projection.



Quick, yielding snap with heavy midrange tonality.  
**RF1P1450S/C**



A sonic dichotomy of versatile crack and guttural punch.  
**RF1P1465S/C**



Low, thunderous wallop with yielding power in play.  
**RF1P1480S/C**

<b>RF1P1450S/C</b>	<b>14" x 5"</b>
SHELL	EvenPly-Six (5.4mm) Maple 4 + Birch 2
HOOPS	MasterCast (DC-1410 / DC-1410S)
LUGS	STL-100
RODS	SST-5047 (20)
STRAINER	SR-1000
SNARES	SN-1420I (Using Cord) (U.S. Patent #7202405)
HEADS	REMO Coated (A)

<b>RF1P1465S/C</b>	<b>14" x 6.5"</b>
SHELL	EvenPly-Six (5.4mm) Maple 4 + Birch 2
HOOPS	MasterCast (DC-1410 / DC-1410S)
LUGS	STL-100
RODS	SST-5047 (20)
STRAINER	SR-1000
SNARES	SN-1420I (Using Cord) (U.S. Patent #7202405)
HEADS	REMO Coated (A)

<b>RF1P1480S/C</b>	<b>14" x 8"</b>
SHELL	EvenPly-Six (5.4mm) Maple 4 + Birch 2
HOOPS	MasterCast (DC-1410 / DC-1410S)
LUGS	STL-100
RODS	SST-5047 (20)
STRAINER	SR-1000
SNARES	SN-1420I (Using Cord) (U.S. Patent #7202405)
HEADS	REMO Coated (A)

## Masters Maple, Masters Maple Pure

With shell recipes from each of the three branches of the Masters Series line-up, Masters Snare Drums' individually versatile nature is prime for the forward-focused drummer. Their collective rhythmic voice sings with the unity of a family of Maple instruments, but with enough tonal variety from model to model to make them totally unique. Available in four sizes and a kaliedescope of dazzling finishes, Masters Snares deliver the excellence you have come to expect from the world's leading drum maker.



Full-Spectrum snare power with thick bottom-end focus.  
**MM6P1465S/C**



Responsive low-range focus with high impact drive.  
**MP4P1450S/C**

<b>MM6P1465S/C</b>	<b>14" x 6.5"</b>
SHELL	6 ply (7.5mm) Maple
HOOPS	MasterCast (DC-1410 / 1410S)
LUGS	CL-65
RODS	SST-5047 (20)
STRAINER	SR-17A / SR-150E
SNARES	SN-1420I (U.S. Patent #7202405)
HEADS	REMO Coated (A)

<b>MP4P1450S/C</b>	<b>14" x 5"</b>
SHELL	4 ply Maple w/4 ply Maple Re-Rings
HOOPS	MasterCast (DC-1410 / 1410S)
LUGS	CL-55
RODS	SST-5047 (20)
STRAINER	SR-17A / SR-150E
SNARES	SN-1420I (U.S. Patent #7202405)
HEADS	REMO Coated (A)

MMG, MM6, & MP4 Snare Drums are Available in 13 x 6.5, 14 x 5, 14 x 6.5, and 14 x 8.

## Professional Series

Professional Series Snare Drums are an exceptional avenue for the gigging pro. Their EvenPly shell fuses six reduced thickness layers of cross-laminated North American Maple for expanded tonal purity, increased resonance, and dramatically different snare sensitivity.



Tried-and-true Maple tone fit for the concert stage.  
**PMX1450S/C**



Deep pocket, low sustain punch without overpowering.  
**PMX1465S/C**

<b>PMX1450S/C</b>	<b>14" x 5"</b>
SHELL	6 ply (5.4 mm) Maple
HOOPS	SuperHoop II (SH-1410 / 1410S)
LUGS	CL-55
RODS	T-062 (20)
STRAINER	SR-017
SNARES	S-022N
HEADS	REMO UT Coated (A)

<b>PMX1465S/C</b>	<b>14" x 6.5"</b>
SHELL	6 ply (5.4 mm) Maple
HOOPS	SuperHoop II (SH-1410 / 1410S)
LUGS	CL-65
RODS	T-061L (20)
STRAINER	SR-017
SNARES	S-022N
HEADS	REMO UT Coated (A)

## Masters Maple Gum

With shell recipes from each of the three branches of the Masters Series line-up, Masters Snare Drums' individually versatile nature is prime for the forward-focused drummer. Their collective rhythmic voice sings with the unity of a family of Maple instruments, but with enough tonal variety from model to model to make them totally unique. Available in four sizes and a kaliedescope of dazzling finishes, Masters Snares deliver the excellence you have come to expect from the world's leading drum maker.



Solid, high-centered tonal punch with full range body.  
**MMGC1465S/C**



Exceptionally well-rounded sound for any groove.  
**MMGP1450S/C**

<b>MMGC1465S/C</b>	<b>14" x 6.5"</b>
SHELL	EvenPly-Six (5.4mm) Maple 4 + Gumwood 2
HOOPS	MasterCast (DC-1410 / 1410S)
LUGS	CL-65
RODS	SST-5047 (20)
STRAINER	SR-17A / SR-150E
SNARES	SN-1420I (U.S. Patent #7202405)
HEADS	REMO Coated (A)

<b>MMGP1450S/C</b>	<b>14" x 5"</b>
SHELL	EvenPly-Six (5.4mm) Maple 4 + Gumwood 2
HOOPS	MasterCast (DC-1410 / 1410S)
LUGS	CL-55
RODS	SST-5047 (20)
STRAINER	SR-17A / SR-150E
SNARES	SN-1420I (U.S. Patent #7202405)
HEADS	REMO Coated (A)



Wide tuning range from thuddy to cracking volume.  
**PMX1480S/C**

<b>PMX1480S/C</b>	<b>14" x 8"</b>
SHELL	6 ply (5.4 mm) Maple
HOOPS	SuperHoop II (SH-1410 / 1410S)
LUGS	CL-100
RODS	T-061L (20)
STRAINER	SR-017
SNARES	S-022N
HEADS	REMO UT Coated (A)

# SERIES COMPONENT

Session, Decade, & President Classic Pearl Sound



DRUM SET SERIES SNARE DRUMS Made to match the sound and feel of your Pearl drum set.



STS1480S/C



STS1465S/C



STS1455S/C



DMP1455/C



PSD1455SE/C



PSD1455SE/C

**STS1480S/C** 14" x 8"

SHELL	EvenPly-Six (5.4mm) Birch / African Mahogany
HOOPS	SuperHoop II (SH-1410 / 1410S)
LUGS	CL-100
RODS	T-061L (20)
STRAINER	SR-017
SNARES	S-022N
HEADS	REMO UT Coated (A)

**STS1465S/C** 14" x 6.5"

SHELL	EvenPly-Six (5.4mm) Birch / African Mahogany
HOOPS	SuperHoop II (SH-1410 / 1410S)
LUGS	CL-65
RODS	T-061L (20)
STRAINER	SR-017
SNARES	S-022N
HEADS	REMO UT Coated (A)

**STS1455S/C** 14" x 5.5"

SHELL	EvenPly-Six (5.4mm) Birch / African Mahogany
HOOPS	SuperHoop II (SH-1410 / 1410S)
LUGS	CL-55
RODS	T-062 (20)
STRAINER	SR-017
SNARES	S-022N
HEADS	REMO UT Coated (A)

**DMP1455S/C** 14" x 5.5"

SHELL	EvenPly-Six (5.4 mm) Maple
HOOPS	1.6mm Steel (RH-1408 / 1408S)
LUGS	NDL-55/C
RODS	TR-5052 (16)
STRAINER	SR-700
SNARES	SNW-1420
HEADS	REMO UT Coated (A)

**PSD1455SE/C** 14" x 5.5"

SHELL	6 ply (7.5mm) Lauan
HOOPS	SuperHoop II (SH-1408 / 1408S)
LUGS	BSL-55
RODS	T-062 (16)
STRAINER	SR-17A / SR-150E
SNARES	SN-1420I (U.S. Patent #7202405)
HEADS	REMO CS
FINISH	#450 Silver Sparkle
INSIDE MUFFLER	IM-100W

**PSD1455SE/C** 14" x 5.5"

SHELL	6 ply (7.5mm) Lauan
HOOPS	SuperHoop II (SH-1408 / 1408S)
LUGS	BSL-55
RODS	T-062 (16)
STRAINER	SR-17A / SR-150E
SNARES	SN-1420I (U.S. Patent #7202405)
HEADS	REMO CS
FINISH	#767 Ocean Ripple
INSIDE MUFFLER	IM-100W

# FREE FLOATING

The Ultimate Purity Of Sound

**TASK-SPECIFIC INNOVATION** Pearl's unique Free Floating Snare chassis removes all hardware from the shell to greatly improve resonance and projection.

By combining the tonal character of each shell type with its ideally matched depth, each Free Floating snare drum is engineered to fit a specific task by model and gives you a unique voice for any sonic situation.

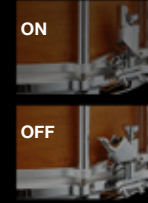

**CLICK-LOCK THROW-OFF SYSTEM** Engineered with Polymer bearings for precise and smooth action. Unique nylon grip mechanism locks the snares into place.



Deep, rich snare power with short, even sustain decay.  
**FTAL1480**



Ultimate in throaty, deep snare growl. Shortened decay.  
**FTMH1480**



Lower overtone body, preserves crisp top-end snare snap.  
**FTPB1465**



Full, rounded bottom frequencies. Extra midrange body.  
**FTMMH1465**



Full-spectrum, both bright in punch and warm in tone.  
**FTBR1450**



Punchy and smooth. A perfect "go-to" snare.  
**FTMM1450**



1mm shell for bright, open attack with ringy overtone.  
**FTSS1435**



Dense all Birch shell delivers bright, open attack.  
**FTBB1435**

**FTAL1480** 14" x 8"

SHELL	1.2mm Seamless Aluminum
HOOPS	MasterCast (DC-1410 / DC-1410S)
LUGS	FT-80
RODS	SST-5042 (20)
STRAINER	SR-160F (U.S. Patent 9082376)
SNARES	SN-1442C (U.S. Patent #7202405)
HEADS	REMO Coated (A)

**FTMH1480** 14" x 8"

SHELL	8 ply (10mm) African Mahogany
HOOPS	MasterCast (DC-1410 / DC-1410S)
LUGS	FT-80
RODS	SST-5042 (20)
STRAINER	SR-160F (U.S. Patent 9082376)
SNARES	SN-1442C (U.S. Patent #7202405)
HEADS	REMO Coated (A)

**FTPB1465** 14" x 6.5"

SHELL	1.2mm Phosphor Bronze
HOOPS	MasterCast (DC-1410 / DC-1410S)
LUGS	FT-65
RODS	SST-5042 (20)
STRAINER	SR-160F (U.S. Patent 9082376)
SNARES	SN-1420C (U.S. Patent #7202405)
HEADS	REMO Coated (A)

**FTMMH1465** 14" x 6.5"

SHELL	6 ply (7.5mm) (4 ply Maple w/2 ply Inner African Mahogany)
HOOPS	MasterCast (DC-1410 / DC-1410S)
LUGS	FT-65
RODS	SST-5042 (20)
STRAINER	SR-160F (U.S. Patent 9082376)
SNARES	SN-1420C (U.S. Patent #7202405)
HEADS	REMO Coated (A)

**FTBR1450** 14" x 5"

SHELL	1mm Brass
HOOPS	MasterCast (DC-1410 / DC-1410S)
LUGS	FT-50
RODS	SST-5042 (20)
STRAINER	SR-160F (U.S. Patent 9082376)
SNARES	SN-1420I (U.S. Patent #7202405)
HEADS	REMO Coated (A)

**FTMM1450** 14" x 5"

SHELL	6 ply (7.5mm) Maple
HOOPS	MasterCast (DC-1410 / DC-1410S)
LUGS	FT-50
RODS	SST-5042 (20)
STRAINER	SR-160F (U.S. Patent 9082376)
SNARES	SN-1420I (U.S. Patent #7202405)
HEADS	REMO Coated (A)

**FTSS1435** 14" x 3.5"

SHELL	1mm Stainless Steel
HOOPS	MasterCast (DC-1410 / DC-1410S)
LUGS	FT-35
RODS	SST-5035 (20)
STRAINER	SR-160F (U.S. Patent 9082376)
SNARES	SN-1420D (U.S. Patent #7202405)
HEADS	REMO Coated (A)

**FTBB1435** 14" x 3.5"

SHELL	6 ply (5.4mm) Birch
HOOPS	MasterCast (DC-1410 / DC-1410S)
LUGS	FT-35
RODS	SST-5035 (20)
STRAINER	SR-160F (U.S. Patent 9082376)
SNARES	SN-1420D (U.S. Patent #7202405)
HEADS	REMO Coated (A)

# SENSITONE HERITAGE ALLOY

## Legendary Snare Tone from Studio to Stage

The Sensitone sound has always been drawn from an amalgamation of The Heritage Alloys (Aluminum, Black-over-Brass, and Steel) for the necessary, immediate tones of yesterday's chart toppers with an undeniably modern sensibility. Sensitone Heritage Alloy snare models employ these three original metal shell types to deliver essential tone and power with the right gig-ready touches.



Dry, focused crack with quick decay.  
**STH1450AL**



Full, guttural snare bellow with little overtone.  
**STH1465AL**



Perfect blend of attack and brassy body.  
**STH1450BR**



An elegant solution for punch and warmth.  
**STH1465BR**



Crisp, sensitive high-pitched snap.  
**STH1450S**



Belting crack with mild midrange overtone.  
**STH1465S**

<b>STH1450AL</b>	14" x 5"
SHELL	1.2mm Beaded Aluminum
HOOPS	SuperHoop II (SH-1410B / 1410S)
LUGS	CL-55
RODS	T-061L (20)
STRAINER	SR-017
SNARES	SN-1420I (U.S. Patent #7202405)
HEADS	REMO Coated (A)

<b>STH1465AL</b>	14" x 6.5"
SHELL	1.2mm Beaded Aluminum
HOOPS	SuperHoop II (SH-1410B / 1410S)
LUGS	CL-65
RODS	T-061L (20)
STRAINER	SR-017
SNARES	SN-1420I (U.S. Patent #7202405)
HEADS	REMO Coated (A)

<b>STH1450BR</b>	14" x 5"
SHELL	1mm Beaded Black Nickel/Brass
HOOPS	SuperHoop II (SH-1410B / 1410S)
LUGS	CL-55
RODS	T-061L (20)
STRAINER	SR-017
SNARES	SN-1420I (U.S. Patent #7202405)
HEADS	REMO Coated (A)

<b>STH1465BR</b>	14" x 6.5"
SHELL	1mm Beaded Black Nickel/Brass
HOOPS	SuperHoop II (SH-1410B / 1410S)
LUGS	CL-65
RODS	T-061L (20)
STRAINER	SR-017
SNARES	SN-1420I (U.S. Patent #7202405)
HEADS	REMO Coated (A)

<b>STH1450S</b>	14" x 5"
SHELL	1mm Beaded Steel
HOOPS	SuperHoop II (SH-1410B / 1410S)
LUGS	CL-55
RODS	T-061L (20)
STRAINER	SR-017
SNARES	SN-1420I
HEADS	REMO Coated (A)

<b>STH1465S</b>	14" x 6.5"
SHELL	1mm Beaded Steel
HOOPS	SuperHoop II (SH-1410B / 1410S)
LUGS	CL-65
RODS	T-061L (20)
STRAINER	SR-017
SNARES	SN-1420I
HEADS	REMO Coated (A)

### THE SR017 STRAINER

Simple and effective, the SR017 is a Pearl standard for effortless snare switching and sensitivity control. Its smooth lever action and fine-tuning knob let you dial in the right amount of snare wire saturation to suit your personal sound.

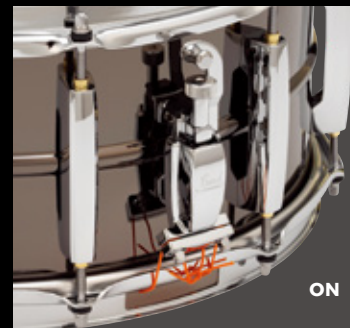
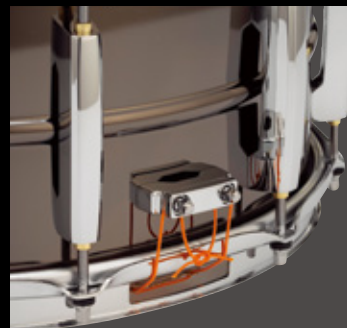

ON

OFF

# SIGNATURE SNARES

## Capturing The Exclusive Sound of Drumming Legends

To be truly great, one must evolve over time. Drumming legend Dennis Chambers took this to heart when considering the transformation of his snare drum sound.

Dennis designed his new Signature Snare for sonic evolution. Using the multi-lug design of his previous model, it employs 10 tuning points on the batter head and eight on the bottom for top-end tonal focus.

Returning to the 4-ply Maple w/ 4-ply Re-Ring shell of his original Signature model, this time in a Matte Black lacquer finish for visual versatility, it features a solid, searing and articulate sound that fits well in any playing field.

The real difference comes with its SR300 Multi-Timbre Strainer that features three individually tunable 6-strand snappy wire snares. Each can be engaged or disengaged to further sculpt the sound of the drum.

Pearl's reliably durable Mastercast Hoops also add weight for increased projection.

*"I got this idea from the Pearl Symphonic series snare drum and I fell in love with the idea of having three different snare settings on one drum."*

- Dennis Chambers



### DENNIS CHAMBERS

<b>DC1465S</b>	14" x 6.5"
SHELL	4 ply Maple w/ 4ply Re-Rings
HOOPS	Mastercast (DC-1410/DC-1408S)
LUGS	STL-100
RODS	SST-5047
STRAINER	SR-300
SNARES	S-051 (x3) Snappy Wire Snares
HEADS	(Evans) B14G12 / S14H30
FINISH	#119 Matte Black Lacquer

A Snare Fit for a Legend, Truly in a Class By Itself.



# SIGNATURE SNARES

Capturing The Exclusive Sound of Drumming Legends



**MATT HALPERN**

<b>MH1460/B</b>	14" x 6"
SHELL	1.5 mm Brass
HOOPS	Mastercast (DCB-1410 / 1410S)
LUGS	STL-55MH/B
RODS	SST-5052 (20)
STRAINER	SR-150B (U.S. Patent #9082376)
SNARES	SN-1420I (U.S. Patent #7202405)
HEADS	Evans Heavyweight Dry
FINISH	Matte Black Lacquer

A Snare Drum from the Outer Limits of the Edge.



**JOEY JORDISON**

<b>JJ1365N</b>	13" x 6.5"
SHELL	1 mm Steel
HOOPS	SuperHoop II (SHB-1308B / 1308S)
LUGS	CL-65B
RODS	SST-5047 (16)
STRAINER	SR-017B
SNARES	S-029N
HEADS	REMO Coated (A)
FINISH	Matte Black Lacquer

A Fierce, Ferocious, Fast Snare fit for a Metal Drumming Legend.



**BRIAN FRASIER-MOORE**

<b>BFM1455S/C</b>	14" x 5.5"
SHELL	12ply (15mm) Gum / Maple / Gum
HOOPS	Mastercast (DC-1410 / 1410S)
LUGS	CL-55
RODS	T-062 (20)
STRAINER	SR-150 (U.S. Patent #9082376)
SNARES	SN-1442I (U.S. Patent #7202405)
HEADS	Evans Power Center
FINISH	Gloss Gumwood Natural Burst

A Truly Inspiring Snare Drum.



**MATT MCGUIRE**

<b>MM1465S/C</b>	14" x 6.5"
SHELL	1 mm Steel
HOOPS	SuperHoop II (SH-1410 / 1410S)
LUGS	CL-65
RODS	T-061 (20)
STRAINER	SR-017
SNARES	SN-1420I (U.S. Patent #7202405)
HEADS	Evans Power Center
FINISH	Matte Black Lacquer

Introducing The World's First "SMART" Snare Drum.



**IAN PAICE**

<b>IP1465</b>	14" x 6.5"
SHELL	1 mm Beaded Steel
HOOPS	SuperHoop II (SH-1410 / 1410S)
LUGS	TB-65
RODS	SST-5042 (20)
STRAINER	SR-017
SNARES	S-022N
HEADS	REMO Coated (A)
FINISH	Chrome

A Timeless, Innovative Collaboration with a True Rock Legend.



**OMAR HAKIM**

<b>OH1350</b>	13" x 5"
SHELL	6 ply (7.5mm) African Mahogany
HOOPS	SuperHoop II (SH-1308 / 1308S)
LUGS	CL-55
RODS	SST-5047 (16)
STRAINER	SR-150 (U.S. Patent #9082376)
SNARES	S-029N
HEADS	REMO Coated (A)
FINISH	#140 Natural Mahogany

A "Power Piccolo" for a Sonic Blend of Power, Projection and Tonal Color.



# HYBRID EXOTIC & ULTRA CAST

**SPACE AGED PRECISION THROUGH ADVANCED SNARE CRAFTING.**

For the ultimate in power and prestige, Pearl's Ultracast Aluminum Snares and limited Hybrid Exotic models offer stark, head-turning voices that stick out from the crowd.



Quick, yielding snap with heavy midrange overtones.  
**HEP1450**



Lively blend of throaty snare holler and punchy projection.  
**HEK1465**



**UCA1450/B**



**UCA1465/B**

<b>HEP1450</b>	14" x 5"
SHELL	VectorCast
HOOPS	SuperHoop II (SH-1410 / 1410S)
LUGS	STL-100
RODS	SST-5047 (20)
STRAINER	SR-1000 (U.S. Patents #7220905 #7365256)
SNARES	SN-1420C (U.S. Patent #7202405)
HEADS	REMO Coated (A)

<b>HEK1465</b>	
SHELL	6 ply (7.5 mm) Kapur w/Inner Fiberglass
HOOPS	SuperHoop II (SH-1410 / 1410S)
LUGS	STL-100
RODS	SST-5047 (20)
STRAINER	SR-1000 (U.S. Patents #7220905 #7365256)
SNARES	SN-1420D (U.S. Patent #7202405)
HEADS	REMO Coated (A)
FINISH	#308/Piano Black w/Pearl Inlay

<b>UCA1450/B</b>	14" x 5"
SHELL	3mm Cast Aluminum w/Reinforcement
HOOPS	SuperHoop II (SHB-1410 / 1410S)
LUGS	TB-50B
RODS	SST-5042 (20)
STRAINER	SR-1000B (U.S. Patents #7220905 #7365256)
SNARES	SN-1420C (U.S. Patent #7202405)
HEADS	Remo Coated (A)

<b>UCA1465/B</b>	14" x 6.5"
SHELL	3mm Cast Aluminum w/Reinforcement
HOOPS	SuperHoop II (SHB-1410 / 1410S)
LUGS	TB-65B
RODS	SST-5042 (20)
STRAINER	SR-1000B (U.S. Patents #7220905 #7365256)
SNARES	SN-1420C (U.S. Patent #7202405)
HEADS	Remo Coated (A)

# DUOLUXE

THE WORLD'S FIRST INLAID BRASS SNARE DRUM

Pearl celebrates three-quarters of a century of iconic drum sounds with Duoluxe, a modern take our legendary Jupiter snare drum. This classic combination of a chrome-over-brass alloy shell and our trademark dual inverted shell beads is augmented with two finish bands of Nicotine White Marine Pearl inlay. This gives the shell a singular look and adds tonal nuance to its unbridled sound.



Bold and crisp with short midrange overtone.  
**DUX1450BR**



Fierce and centered mid-to-low sustain.  
**DUX1465BR**

<b>DUX1450BR</b>	14" x 5"
SHELL	1mm Dual-Beaded Chrome/Brass
HOOPS	SuperHoop II (SH-1410B/1410S)
LUGS	BSL-55
RODS	SST-5042 (20)
STRAINER	SR-017
SNARES	SN-1420I (U.S. Patent #7202405)
HEADS	REMO Coated (A)
FINISH	INLAY: #405 Nicotine White Marine Pearl (x2)

<b>DUX1465BR</b>	14" x 6.5"
SHELL	1mm Dual-Beaded Chrome/Brass
HOOPS	SuperHoop II (SH-1410B/1410S)
LUGS	BSL-55
RODS	SST-5055 (20)
STRAINER	SR-017
SNARES	SN-1420I (U.S. Patent #7202405)
HEADS	REMO Coated (A)
FINISH	INLAY: #405 Nicotine White Marine Pearl (x2)

# STAVECRAFT

A startling addition to any pro drummer's soundscape, each StaveCraft shell starts from two layers of meticulously beveled solid wood staves. Dado-Loc, an old world principal exclusive to these snares, inserts a solid segment of contrasting wood into the center Dado channel formed by each staff. This solid fusion of hardwoods is lathed to a perfectly round 25mm thickness for unparalleled volume and power.



Peak high-end sonic dominance with lively overtone.  
**SCD1450AW**



Dense, strident snare power with full-compass swagger.  
**SCD1465AW**

<b>SCD1450AW</b>	14" x 5"
SHELL	25mm Dual Ash Wood Stave w/ Makha DadoLoc
HOOPS	Mastercast (DC-1410 / 1410S)
LUGS	STL-55L
RODS	SST-5042 (20)
STRAINER	SR-150 (U.S. Patent 9082376)
SNARES	SN-1420I (U.S. Patent #7202405)
HEADS	Remo USA CS Black Dot Clear

<b>SCD1465AW</b>	14" x 6.5"
SHELL	25mm Dual Ash Wood Stave w/ Makha DadoLoc
HOOPS	Mastercast (DC-1410 / 1410S)
LUGS	STL-65
RODS	SST-5042 (20)
STRAINER	SR-150 (U.S. Patent 9082376)
SNARES	SN-1420I (U.S. Patent #7202405)
HEADS	Remo USA CS Black Dot Clear



Quick, tight high-range tonal power.  
**SCD1450TO**



Sensitive, centered low-overtone drive.  
**SCD1465TO**

<b>SCD1450TO</b>	14" x 5"
SHELL	25 mm Dual Thai Oak Stave w/ Makha DadoLoc
HOOPS	Mastercast (DC-1410 / 1410S)
LUGS	STL-55L
RODS	SST-5042 (20)
STRAINER	SR-150 (U.S. Patent 9082376)
SNARES	SN-1420I (U.S. Patent #7202405)
HEADS	Remo USA CS Black Dot Clear

<b>SCD1465TO</b>	14" x 6.5"
SHELL	25 mm Dual Thai Oak Stave w/ Makha DadoLoc
HOOPS	Mastercast (DC-1410 / 1410S)
LUGS	STL-65
RODS	SST-5047 (20)
STRAINER	SR-150 (U.S. Patent 9082376)
SNARES	SN-1420I (U.S. Patent #7202405)
HEADS	Remo USA CS Black Dot Clear



Cracking tonal pop with short midrange hum.  
**SCD1450MK**



Thick, cavernous sonic body with cutting punch.  
**SCD1465MK**

<b>SCD1450MK</b>	14" x 5"
SHELL	25 mm Dual Makha Stave w/ Thai Oak DadoLoc
HOOPS	Mastercast (DC-1410 / 1410S)
LUGS	STL-55L
RODS	SST-5042 (20)
STRAINER	SR-150 (U.S. Patent 9082376)
SNARES	SN-1420I (U.S. Patent #7202405)
HEADS	Remo USA CS Black Dot Clear

<b>SCD1465MK</b>	14" x 6.5"
SHELL	25 mm Dual Makha Stave w/ Thai Oak DadoLoc
HOOPS	Mastercast (DC-1410 / 1410S)
LUGS	STL-65
RODS	SST-5047 (20)
STRAINER	SR-150 (U.S. Patent 9082376)
SNARES	SN-1420I (U.S. Patent #7202405)
HEADS	Remo USA CS Black Dot Clear



# UTILITY

## VERSATILE DRUMS FOR SECONDARY EFFECTS

**MODERN UTILITY** snare drums are vital instruments. Well-appointed tools of the trade crafted for the informed, current drummer to make the gig great. Priced for the active working player, Modern Utility snares are available in both 100% Maple and Beaded Steel. Flexible enough to add to any setup and strong enough to stand up to constant play, each model has a cool, versatile vibe. Featuring our CL arch lugs and smooth SR700 snare strainer for precise tunability.

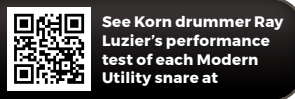

See Korn drummer Ray Luzier's performance test of each Modern Utility snare at



MUS1480M



MUS1410FM

Leg Brackets:  
FTB-07 (x3)



MUS1455M



MUS1465M



MUS1350M



MUS1270M

MUS1480M	14" x 8"
SHELL	6 ply (5.4mm) Maple
HOOPS	1.6mm Steel (RH-1408 / 1408S)
LUGS	CL-100
RODS	TR-5047 (16)
STRAINER	SR-700
SNARES	SNW-1420
HEADS	REMO UT Coated (A)
FINISH	#224 Matte Natural, #227 Satin Black

MUS1410FM	14" x 10"
SHELL	6 ply (5.4mm) Maple
HOOPS	1.6mm Steel (RH-1408 / 1408S)
LUGS	CL-100
RODS	TR-5047 (16)
STRAINER	SR-017
SNARES	SNW-1420
HEADS	REMO UT Coated (A) w/Ring Mute
FINISH	#220 Satin Brown

MUS1455M	14" x 5.5"
SHELL	6 ply (5.4mm) Maple
HOOPS	1.6mm Steel (RH1408 / 1408S)
LUGS	CL-55
RODS	TR-5052 (16)
STRAINER	SR-700
SNARES	SNW-1420
HEADS	REMO UT Coated (A)
FINISH	#224 Matte Natural, #227 Satin Black

MUS1465M	14" x 6.5"
SHELL	6 ply (5.4mm) Maple
HOOPS	1.6mm Steel (RH-1408 / 1408S)
LUGS	CL-65
RODS	TR-5047 (16)
STRAINER	SR-700
SNARES	SNW-1420
HEADS	REMO UT Coated (A)
FINISH	#224 Matte Natural, #227 Satin Black

MUS1350M	13" x 5"
SHELL	6 ply (5.4mm) Maple
HOOPS	1.6mm Steel (RH-1308 / 1308S)
LUGS	CL-55
RODS	TR-5047 (16)
STRAINER	SR-700
SNARES	SNW-1316
HEADS	REMO UT Coated (A)
FINISH	#224 Matte Natural, #227 Satin Black

MUS1270M	12" x 7"
SHELL	6 ply (5.4mm) Maple
HOOPS	1.6mm Steel (RH1-206 / 1206S)
LUGS	CL-65
RODS	TR-5057 (12)
STRAINER	SR-700
SNARES	SNW-1216
HEADS	REMO UT Coated (A)
FINISH	#224 Matte Natural, #227 Satin Black

### EFFECTS SNARES



M1060 10" x 6"

SHELL	6 ply (7.5mm) Maple
HOOPS	SuperHoop II (SH-1006 / 1006S)
LUGS	CL-65
RODS	SST-5047 (16)
STRAINER	SR-018
SNARES	S-032N
HEADS	REMO Coated (A)
FINISH	#102 Natural Maple



M1270 12" x 7"

SHELL	8 ply (10.0 mm) Maple
HOOPS	1.6mm Steel (RIM-1208B / 1208S)
LUGS	CL-100
RODS	SST-5047 (16)
STRAINER	SR-018
SNARES	S-031N
HEADS	REMO Coated (A)
FINISH	#114 Liquid Amber



SFS1335B 13" x 3.5"

SHELL	Steel
HOOPS	1.6mm Steel
LUGS	MSFL35
RODS	RSH1-3235
STRAINER	SRO2MSFL/SRO2EMSFL
SNARES	SN-13MSFL
HEADS	JH-13C
FINISH	Matte Black

### PICCOLO



S1330 13" x 3"

SHELL	1mm Brass
HOOPS	1.6mm Steel (RIM-1308B / 1308S)
LUGS	CL-05
RODS	T-055 (16)
STRAINER	SR-018
SNARES	S-029N
HEADS	REMO Coated (A)
FINISH	---



S1330B 13" x 3"

SHELL	1mm Steel
HOOPS	1.6mm Steel (RIM-1308B / 1308S)
LUGS	CL-05
RODS	T-055 (16)
STRAINER	SR-018
SNARES	S-029N
HEADS	REMO Coated (A)
FINISH	Black Finish



M1330 13" x 3"

SHELL	6 ply (7.5 mm) Maple
HOOPS	1.6mm Steel (RIM-1308B/1308S)
LUGS	CL-05
RODS	T-055 (16)
STRAINER	SR-018
SNARES	S-029N
HEADS	REMO Coated (A)
FINISH	#114 Liquid Amber, #102 Natural Maple

### FIRECRACKER



FCP1250 12" x 5"

SHELL	8 ply (10.0 mm) Poplar
HOOPS	1.6mm Steel (RIM-1206/1206SL)
LUGS	CL-55 (with Steel Nut)
RODS	T-061L (12)
STRAINER	SR-018
SNARES	S-031
HEADS	PTH12C
FINISH	#271 Ebony Mist



FCS1050 10" x 5"

SHELL	Steel
HOOPS	1.6mm Steel (RIM-1006/1006SL)
LUGS	CL-55 (with Steel Nut)
RODS	T-061L (12)
STRAINER	SR-018
SNARES	S-032
HEADS	PTH10C
FINISH	Chrome Plating

# EFFECTS

**THE IGNITER** To capture the searing energy of drumming for a new generation of players, Pearl collaborated with viral video drummer Casey Cooper to create The Igniter. Specifically created to instantly improve the sound of any student drum kit, it's a fantastic value to keep the fire of drumming burning bright!



CC1450S/C	14" x 5"
SHELL	6 ply (6.8mm) Poplar / Maple
HOOPS	1.6mm Steel (RH1408 / 1408S)
LUGS	CL55
RODS	TR5047 (16)
STRAINER	SR700
SNARES	SNW1420
HEADS	REMO UT Coated (A)
FINISH	Artisan II Flame Finish

COLLABORATION CASEY COOPER @COOP3RDRUMM3R



e/TRADITIONAL CONFIGURATION

10", 12" and 14" toms, a 14" snare, and PUREtouch Kick Pad. PUREtouch Cymbals, ICON e-Rack, MDL1 Module. EM-53T



e/HYBRID CONFIGURATION

EM-HWP  
The foundation of the e/MERGE electronic drum set is a custom designed, chrome plated ICON e-Rack system.

10", 12" and 14" toms, 14" snare, and 18" acoustic bass drum. PUREtouch Cymbals, ICON e-Rack, MDL1 Module. EM-53HB

## e/MERGE

**NOT JUST A NEW STANDARD.  
A NEW SOUND. A NEW FEEL. AND, A  
COMPLETELY NEW E-DRUMMING EXPERIENCE.**

e/MERGE is about change, and change in the e-drum market has been way overdue. When we looked closely at every aspect of the current e-drumming experience with KORG, together we knew we could make a dramatic difference. And that difference begins with the all new e/MERGE module. Simple yet elegant in design, the e/MERGE MDL1 module features a full library of high definition, natural, organic and minimally processed acoustic Pearl drums. We then added the very best electronic, world, orchestral and specialty percussion sounds from KORG's vast library of pristine quality samples. But, the module is only part of the change.

There are three key elements that separate e/MERGE from anything that has come before. The MDL1 e/MERGE Module, KORG's amazing WAVE TRIGGER TECHNOLOGY and Pearl's acoustic-like PUREtouch electronic pads and cymbals combine to create an exceptional e-drumming experience.

EM-MDL1



**e/MERGE MDL1 MODULE** Simple, straight forward yet extremely powerful, the MDL1 module offers, a pair of powerful multicore processors, a full library of acoustic Pearl drums recorded in one of the world's most renowned studios, pristine samples from KORG's library and the variety of routing options every e-drummer needs.



**WAVE TRIGGER TECHNOLOGY** This ultra-fast and highly sensitive technology partially based upon KORG's groundbreaking Wave Drum allows even your stick choice to make a discernible difference in the sound of your drum. Wave Trigger Technology speed adds a realism to the playing experience never before available to the e-drummer.

## PUREtouch

**PUREtouch PADS & CYMBALS** Perfectly sized pads designed to replicate the ultimate acoustic-like response. PUREtouch features layer upon layer of specially designed materials each selected for a specific quality that together create an e-experience never before possible.

### MODULE SPECIFICATIONS

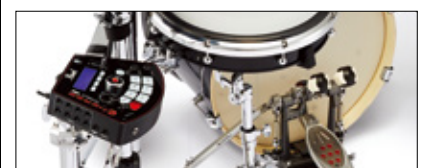

<b>SOUND GENERATOR</b>	2 CPU (4 core + 2 core)
<b>POLYPHONY</b>	128 Voices
<b>VOICE</b>	700 HD Sound Library
<b>DRUM KIT</b>	35 HD Kits
<b>EFFECTS</b>	36
<b>SONG RECORDING TYPE</b>	44.1kHz, 16 Bit WAV
<b>SONG RECORDING TIME</b>	Approximately 12 Hours
<b>CLICK TEMPO</b>	BPM 30 - 300
<b>BEAT</b>	1/2 - 24/2, 1/4 - 24/4, 1/8 - 24/8, 1 - 24/8T, 1/16 - 24/16 (T=Triplet)
<b>CLICK VOICES</b>	10
<b>CONTROLLERS</b>	Knobs and Ambient Slider Control
<b>DISPLAY</b>	3.25" x 1" Graphic LCD
<b>CONNECTORS</b>	Master Out L/Mono & R Direct Out (8) Headphones Out Aux In TRS Mini Main Trigger inputs (DB-25 Connector) Accessory Inputs (3)
<b>MIDI</b>	USB to PC Port (Transport USB Audio & MIDI Data) USB-A (for WAV files and Settings Data)
<b>POWER SUPPLY</b>	MIDI Output
<b>DIMENSIONS, WEIGHT</b>	100-120V, 50-60Hz, Switching Power Supply 2.2lbs, 9" W x 7.5" D x 2" H

# MIMIC PRO

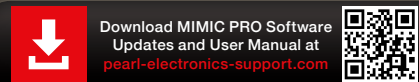

Powered by Slate



MIMP24B

## MIMIC PRO POWERED BY SLATE

### STATE OF THE ART FEATURES:

- 7" IPS Touch Screen with Programmable Data Wheel
- 120GB Solid State drive
- 16 Dual Zone Inputs
- 16 Programmable Audio Outputs
- MIDI In and Out
- High Quality Digital to Analog Converters
- Two completely separate mixers for headphone and Main outs (Drummer gets a personal mix with and without effects independent of Main outputs)
- Import Wave, Aiff or MP3 sound files
- Compatible with most pads on the market
- Steven Slate Drums 5 Library
- 24 bit multi channel sample library with separate adjustment of Close, Overhead and Room mics
- Onboard effects include EQ, Compression, Reverb with Room Sizes
- Individual Cymbal Volume Adjustments for Bell, Bow, Edge, Chik and Splash
- All AUX and Cymbal inputs have choke function
- Supports triple and dual zone cymbals and dual zone hi hat
- SD card slot and USB
- Additional Instruments and Libraries will be available
- Stereo Aux In and Onboard Metronome
- Internal Recording for Loops and/or Performances

**THE MOST AMAZING  
DRUM MODULE  
THE WORLD HAS  
EVER KNOWN.**

**SERIOUSLY,  
IT'S THAT GOOD.**



Superior sound, accurate triggering and connectivity are the most important features of a drum module. Pearl Drums and Steven Slate have joined forces to create "Mimic Pro" - the world's most advanced percussion sound source for studio and live performance applications.

At the heart of this ground breaking unit is the new Steven Slate 5 drum library that features multi-channel drum samples recorded in world class studios. Each instrument supports adjustment of Attack, Sustain, Release, Tune, Pan and volume. Instead of substituting digital effects to create ambience, these instruments use the actual ambient recordings with separate adjustment of close, overhead and room mics.

Mimic Pro is the first drum module to implement a 7" IPS touch screen and the first to offer 2 mixers for independent headphone and front house outputs. Now that the drummer is responsible for triggering loops and other sounds for a performance, Mimic Pro can import audio files to trigger from your pads.

Storage is no longer a problem with Mimic's 120GB Solid State Drive and lightning fast loading time. Speaking of connectivity, Mimic Pro is compatible with Pearl TruTrac pads and a host of pads from other manufacturers. Top that off with sixteen audio outs, 16 Trigger inputs, independent SD card Slot, USB and Midi In & Out, Stereo Aux input and you would be hard pressed to find a better option for today's musician.



# malletSTATION

The World's First 3.0 Octave Adjustable Range  
Electronic Mallet Controller

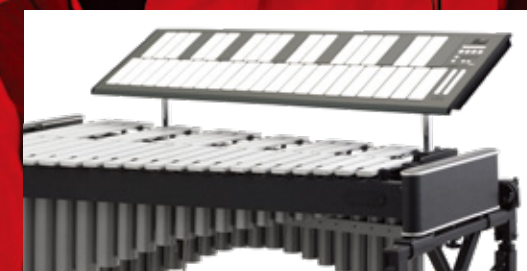
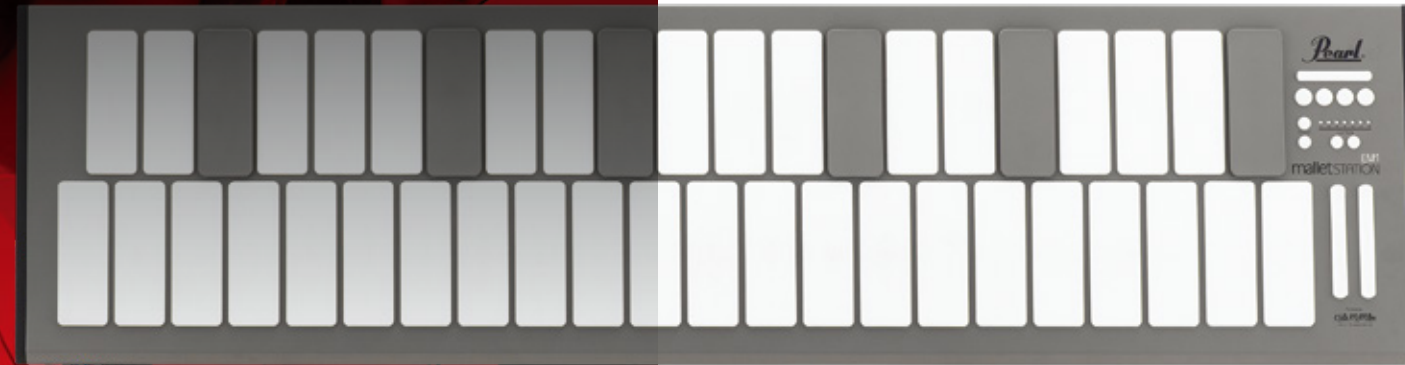

Shown Mounted on Vibraphone with Field Frame

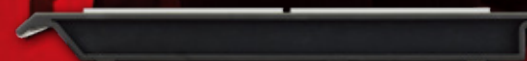

Sleek, modern design with an ultra thin 1.6" profile

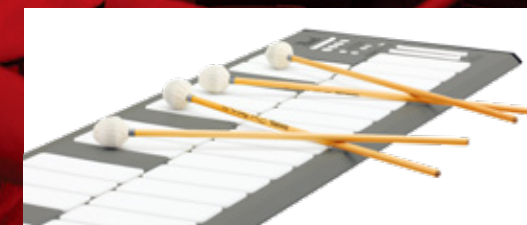

1.75" x 5" Soft Silicone Keys powered by KMI Smart Fabric Sensor Technology

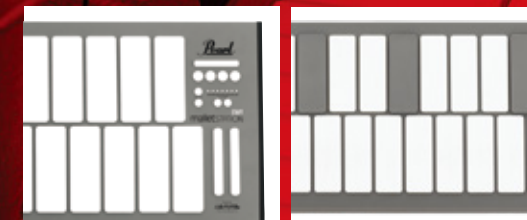

Software Assignable Control Panel with 3 Faders, 4 Buttons, plus Low Note and Octave Shift (U.S. Patent 10311841)

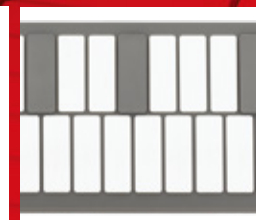

Moveable Accidental "Gap Caps" for visual cues when low note range is adjusted



Jack panel with USB MIDI, MIDI expander port, and 3 MIDI assignable 1/4" pedal inputs



Optional Dual Module Mounts allow malletSTATION to easily mount on racks, stands, and field frames

## malletSTATION™ EM-1

**PRACTICE, PERFORM, COMPOSE ANYWHERE.**

- USB Powered MIDI Mallet Keyboard Controller
- Universal Compatibility through phone/tablet/laptop
- Tech-Forward Design featuring KMI Smart Fabric Sensors
- Low Note, Adjustable, User defined
- Customizable mallet dampening and aftertouch modes for realistic performance techniques
- Natural feeling soft silicone keys, all-weather playing surface
- Assignable buttons and faders for customized control and functions
- Three assignable pedal inputs for expression and sustain
- Hybrid Aluminum and Steel Chassis design for durability and stability
- Optional MIDI Expander to use external MIDI Hardware (sold separately)
- Flexible mounting on desktop, X-stand, or module mounts (sold separately)
- Mounting plates, stands, cases, covers, and other peripherals (available separately)

- 43, 1.75" x 5" soft silicone keys
- 3 faders and 4 buttons, MIDI assignable
- 3 MIDI assignable 1/4" pedal inputs
- Bottom Note Range Shift up/down buttons
- Octave up/down buttons
- 1.6" H x 12.6" W x 49" L
- 22.5 lbs

Pearl once again redefines the electronic percussion experience by introducing the revolutionary EM1 malletSTATION adjustable range electronic mallet controller.

The EM1 malletSTATION is a 3.0 octave adjustable range electronic mallet controller designed for all levels of player, from the beginning student through the gigging professional. The adjustable range function allows you to set the fundamental diatonic note of the instrument to what you need—low D xylophone? No problem! Powered exclusively by USB Bus Power, the malletSTATION is designed to be used with Mac, PC, iPad, iPhone, and Android devices, making it the first truly portable mallet percussion controller on the market.

Designed in collaboration with Keith McMillen Instruments, malletSTATION's tech-forward design features KMI's Smart Fabric Sensor technology allowing the silicone bar material to have an extremely sensitive, natural response, including mallet dampening and aftertouch control, and all can be easily tailored to your individual playing style. The EM1 features a master control section, with 3 programmable faders, 4 programmable buttons, and the fixed function low note and octave shift buttons. In addition, three assignable pedal inputs allow for flexibility in performance such as sustain, expression, or any MIDI parameter of your choice. These controls are fully programmable through a software editor so changing your configuration is as easy as clicking a mouse.

This is the controller that will grow with you throughout your playing career—from music apps on your phone or tablet, to professional digital audio workstations and sound libraries—your sounds and even the instruments you play are only limited by the software you run.

# ELIMINATOR DEMON XR



SEE the **Demon XR** in action with design partner George Kollias and John Longstreth

The Ultimate In Speed, Rebound, And Accuracy.



**ENHANCED REBOUND STROKE**  
Eases High Tempo Single and Double Strokes



**DIRECT DRIVE**  
Extreme Speed and Precise, Resistance-Free Playability



**SLEEK LONGBOARD**  
Improves Double Stroke Response

**MACHINED ALUMINUM CONSTRUCTION**  
Delivers Light, Efficient Action

Single Pedal Complete  
**P-3500D**

## THE DIRECT-DRIVE TRIPLE THREAT: X-TREME SPEED. X-TREME REBOUND. X-TREME ACCURACY.

Developed in conjunction with the world's top drumming talents for speed and enhanced rebound in extreme musical situations, The Pearl Demon XR Bass Drum Pedal is your direct path to rapid fire bass drum performance.

Delivering the ultimate in Speed, Rebound, and Accuracy, the Pearl Demon XR (for X-treme Response) Bass Drum Pedal is a true Triple Threat in bass drum pedal performance.

### P-3500D BASS DRUM PEDAL

DRIVE	Direct Drive
FOOT BOARD	Longboard Machined Aluminum
DRIVE BEARINGS	NiNJA Low-Friction Extreme High-Tension Spring (Normal Spring included)
SPRING	Extreme Impact Beater (B-350XR)
BEATER	Click-Lock
TENSION ADJUSTMENT	Included
CASE	Pivoting Hoop Clamp
HOOP CLAMP	Included

### P-3502D DOUBLE BASS DRUM PEDAL

DRIVE	Direct Drive
FOOT BOARD	Longboard Machined Aluminum
DRIVE BEARINGS	NiNJA Low-Friction Extreme High-Tension Spring (Normal Spring included)
SPRING	Extreme Impact Beater (B-350XR)
BEATER	Click-Lock
TENSION ADJUSTMENT	Included
CASE	Pivoting Hoop Clamp
HOOP CLAMP	Included
UNIVERSAL JOINT	Z-Link Drive Shaft



**Z-LINK**  
Universal Linkage



**X-TREME IMPACT BEATER**  
Sharp Attack and Low End

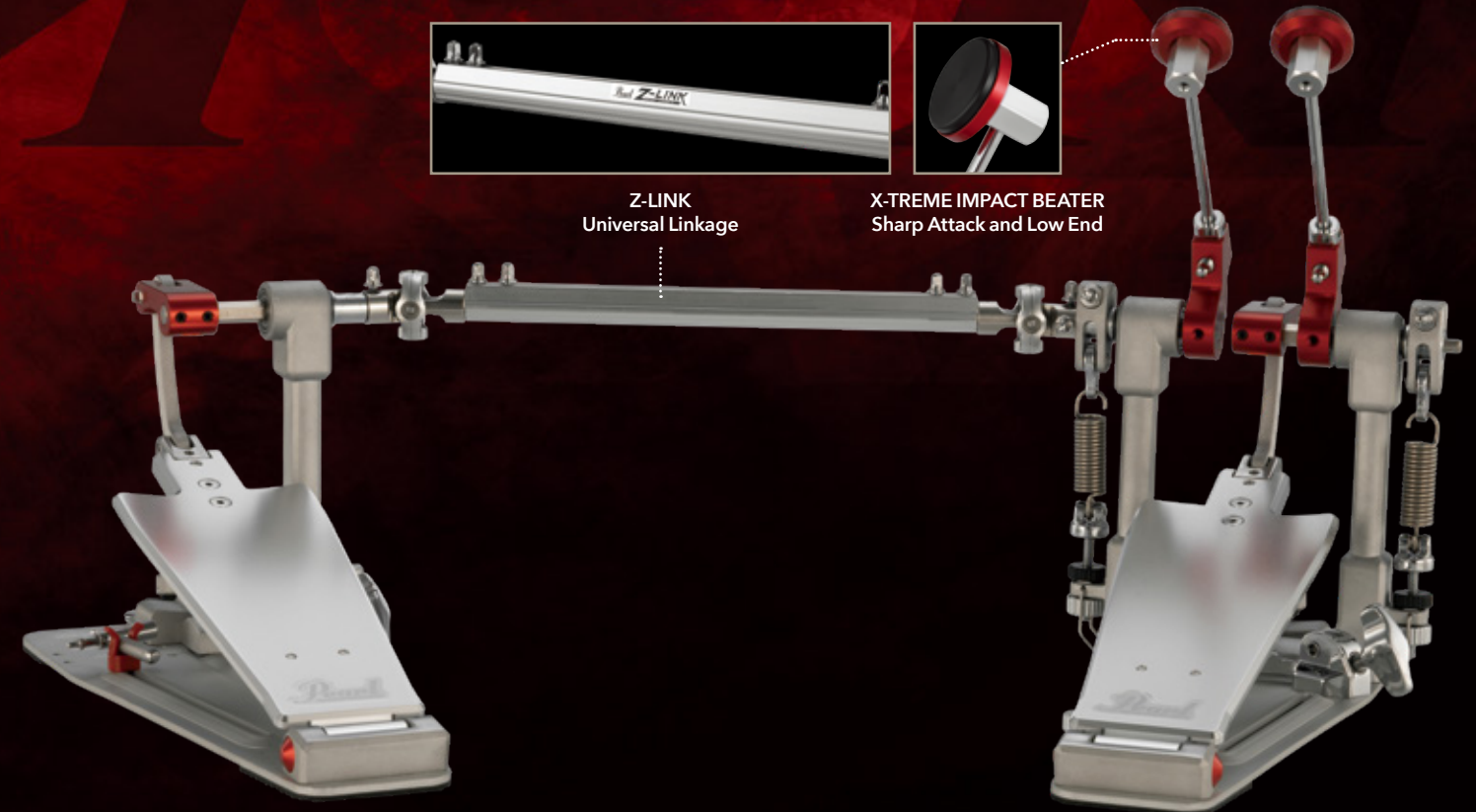

Double Pedal Complete  
**P-3502D**



#### X-TREME SPEED

Its streamlined machine shop design is the result of a two-year research and development project with drummer George Kollias, and delivers a faster, smoother stroke in action.



#### X-TREME REBOUND

The key to higher playing speed is in its enhanced rebound action and interchangeable Extreme Spring. This exclusive feature makes repeated strokes in the most extreme musical situations effortless.



#### X-TREME ACCURACY

Primed for the high tempo technicality, the Pearl Demon XR is perfect for any drumming style where precision and endurance is key.

# DEMON PEDALS

The Fastest, Smoothest, Most Powerful Pedals in the World

## DEMON DRIVE UNLEASH THE DEMON

Demon Drive's lightning fast power and silky smooth finesse make it the choice of the drumming world's most prolific players. Featuring an amazing array of adjustable features, from beater angle, traction plate grip, and footboard height and angle, Demon Drive truly becomes an extension of your body. Its totally modular design makes it configurable in a variety of single and double pedal setups. Unleash the Demon and find out what custom feel is all about.



U.S. Patent #7579540

A choice of 2 positions for a finesse or power feel. Simply loosen the clamshell to change position.

- Single Pedal Complete P-3000D
- Double Pedal Complete (right footed) P-3002D
- Double Pedal Conversion Kit (right footed) P-3001D
- Double Pedal Complete (left footed) P-3002DL

- Demon Drive (Shown in Shortboard Set Up) P-3000D

Demon Drive (Shown in Shortboard Set Up) P-3000D



**DIRECT LINK** Dual position adjustment for LIGHT or HEAVY feel, creating a seamless link between your foot and the bass drum.



**CLICK-LOCK** Secures spring tension in high impact play. (U.S. Patent #7754953)



**DUO-DECK FOOTBOARD** The world's first convertible footboard can switch from a traditional shortboard to a longboard pedal in seconds. (U.S. Patent #7626107)

CONTROL CORE BEATERS

INDEPENDENT BEATER ANGLE AND FOOTBOARD HEIGHT ADJUSTMENTS

ADJUSTABLE TRACTION PLATE

Direct Drive Double Pedal (Shown in Longboard Setting) P-3002D

### P-3000D / P-3002D DEMON DRIVE

DRIVE	Direct Drive
FOOT BOARD	Duo-Deck Convertible
DRIVE BEARINGS	NiNJA Low-Friction
BEATER	Control Core
TENSION ADJUSTMENT	Click-Lock
FOOTBOARD ANGLE	Infinitely Adjustable
BEATER ANGLE	Infinitely Adjustable
CASE	Included
HOOP CLAMP	Pivoting Hoop Clamp

DUO-DECK FOOTBOARD

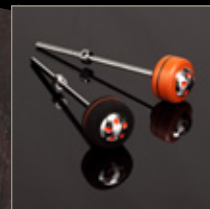

**DEMON DRIVE BEATER** w/ Control Core Elastomer Center. Reduces impact vibration. (U.S. Patent #7626108)

## NiNJA



**NiNJA BEARINGS** Designed for Pro Skateboarding, each bearing features micro-polished balls for minimal friction and unmatched speed.

# ELIMINATOR DEMON PEDALS

HEAVENLY FEEL... WICKEDLY FAST

## DEMON CHAIN TRADITIONAL FEEL AND POWER OF A CHAIN

An innovative combination of Demon Drive speed and traditional chain drive feel, the Demon Chain's Perfect Circle cam delivers smooth, consistent response throughout the stroke for pinpoint accuracy and control. A high performance package for the driven power drummer.

PERFECT CIRCLE CAM

PIVOTING HOOP CLAMP

MULTI FUNCTION DRUM KEY

- Single Pedal Complete P-3000D
- Double Pedal Complete (right footed) P-3002D
- Double Pedal Conversion Kit (right footed) P-3001D
- Double Pedal Complete (left footed) P-3002DL

- Demon Chain (Shown in Longboard Set Up) P-3000C



**PERFECT CIRCLE CAM** Its racing inspired lines transfer energy from your foot into the head with minimal mass and maximum speed.

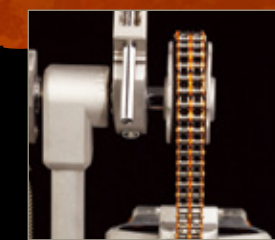

**POWER CHAIN** This ultra lightweight, dual linkage Chain features low friction rollers for power and dependability.



Chain Drive Double Pedal (Shown in Shortboard Setting) P-3002C



**Z-LINK DRIVE SHAFT** Delivering the same precise action of the primary pedal in the secondary pedal, the Z-Link features hand assembled, CNC machined construction. Features Pearl's exclusive Zero Latency Universal Joints, and precision radial ball bearings.

### P-3000C / P-3002C DEMON CHAIN

DRIVE	Ultralight Chain
FOOTBOARD	Duo-Deck Convertible
DRIVE BEARINGS	NiNJA Low-Friction
DRIVE CAM	Perfect Circle "Linear Response" Cam
BEATER	Control Core
TENSION ADJUSTMENT	Click-Lock
FOOTBOARD ANGLE	Infinitely Adjustable
BEATER ANGLE	Infinitely Adjustable
CASE	Included
HOOP CLAMP	Pivoting Hoop Clamp

BEATER HEIGHT ADJUSTMENT

NiNJA BEARINGS

# ELIMINATOR : REDLINE

## CHOOSE A CAM

### REDLINE YOUR PERFORMANCE

The world's only pedal featuring the Patented Interchangeable Cam System, Eliminator: Redline's virtually unlimited tunability lets you lock in personally tuned feel, power, and speed. Like having four pedals in one, Redline pushes the boundaries of bass drum performance by fusing the power and flexibility of Pearl's original Eliminator with the fluid speed of our Demon series pedals.

The Key to Ultimate Bass Drum Performance

## ELIMINATOR REDLINE

CHAIN OR BELT DRIVE \*Shown w/ Optional Red Cam



The sprocketless double chain drive on the Eliminator Redline (P-2050C) provides super smooth action with powerful and precise feel. The Eliminator Belt Drive model (P-2050B) provides a very comfortable, natural feel similar to a direct-drive system.



Eliminator Redline Double Pedal Chain Drive (Shown w/ Included Red Cam Attached) P-2052C

Eliminator: Redline Series pedals come standard with Custom Carry bags.



Eliminator: Redline Single Pedal, Chain Drive P-2050C

	P-2050C ELIMINATOR: REDLINE CHAIN	P-2052C ELIMINATOR: REDLINE DOUBLE PEDAL, CHAIN	P-2050B ELIMINATOR: REDLINE, BELT	P-2052B ELIMINATOR: REDLINE DOUBLE PEDAL, BELT
Drive	Sprocketless Double Chain	Sprocketless Double Chain	Steel-Reinforced Rubber Strap	Steel-Reinforced Rubber Strap
FOOT BOARD	Redline Reversible Traction Plate	Redline Reversible Traction Plate	Redline Reversible Traction Plate	Redline Reversible Traction Plate
DRIVE BEARINGS	NiNJA Low-Friction	NiNJA Low-Friction	NiNJA Low-Friction	NiNJA Low-Friction
DRIVE CAM	Interchangeable Cam	Interchangeable Cam	Interchangeable Cam	Interchangeable Cam
BEATER	Control Core Quadbeater	Control Core Quadbeater	Control Core Quadbeater	Control Core Quadbeater
TENSION ADJUSTMENT	Click-Lock	Click-Lock	Click-Lock	Click-Lock
BEATER ANGLE	Uni-Lock Beater Angle Cam	Uni-Lock Beater Angle Cam	Uni-Lock Beater Angle Cam	Uni-Lock Beater Angle Cam
POWERSHIFTER	Three Position	Three Position	Three Position	Three Position
CASE	Included	Included	Included	Included
HOOP CLAMP	Roller Cam Hoop Clamp	Roller Cam Hoop Clamp	Roller Cam Hoop Clamp	Roller Cam Hoop Clamp
UNIVERSAL JOINT	---	Length Adjustable, Latency-Free	---	Length Adjustable, Latency-Free

## ELIMINATOR REDLINE

## INTERCHANGEABLE CAM SYSTEM

Provides a choice of 6 different color-coded cams (4 included and 2 more optional). Quickly changes the power and feel of the pedal to suit your individual playing needs. Changing the cam is as simple as pushing the release button and snapping another in place.

**FEEL** (Strong to Light)

**BEATER ACTION**

- BLACK CAMT-BK**: Linear action cam
- WHITE CAMT-WT**: Oversized linear cam
- BLUE CAMT-BL**: Progressive cam
- RED CAMT-RD**: Radical progressive cam
- PURPLE CAM-PL**: Aggressive action cam (Optional)
- YELLOW CAM-YL**: Inverse action cam (Optional)

# ELIMINATOR : REDLINE L.T. (Light Transport)

The Eliminator Redline LT (Light-Transport) is the new high-end bass drum pedal that you can fold and transport easily with popular features from the best selling "Eliminator Redline" series. Featuring core specifications such as the NiNJA bearing, the Eliminator Redline LT is extremely comfortable to play with a light and smooth action.

P-2050C/F ELIMINATOR: REDLINE L.T. (Light Transport)	
Drive	Sprocketless Double Chain
FOOT BOARD	Redline Reversible Traction Plate
DRIVE BEARINGS	NiNJA Low-Friction
DRIVE CAM	Interchangeable Cam
BEATER	Control Core Quadbeater
TENSION ADJUSTMENT	Click-Lock
BEATER ANGLE	Uni-Lock Beater Angle



**POWERSHIFTER FUNCTION**  
By moving the foot board forward or back, our revolutionary Powershifter function provides 3 positions to fine tune the power and feel of the pedal. Instantly change the drive angle leverage to create a light, regular, or strong feel.



**NINJA BEARINGS** Developed by skateboarding engineers for the ultimate in fast, quiet performance, NiNJA Bearings incorporate state of the art micropolished steel balls for incredibly fast and smooth performance.



**INDEPENDENT TRACTION GRIPS**  
Eliminator Redline's redesigned pedalboard features Pearl's exclusive reversible Traction Plate insert, allowing individual traction grip configuration to suit your exact playing requirements.



**CLICK-LOCK SPRING ADJUSTMENT** w/ NEW Rotor Tension Cradle. Secures spring tension in high impact play. The counter spring adjustment's rolling cradle allows the spring to pivot with each stroke for less resistance. (U.S. Patent #7754953)



**ZERO PLAY HINGE**  
Our proprietary stainless steel hinge provides maximum freedom of motion for blazing speed and prevents play between the footboard and heel. U.S. Patent #7179978



**ROLLER CAM HOOP CLAMP**  
Mount Adjustment. Quickly adapts to a wide range of hoop thicknesses for the smoothest, most secure grip possible. Easy side access to the hoop clamp makes set up and tear down a breeze.



**THE CONTROL CORE QUADBEATER**  
Provides four beater surfaces (two hard plastic, two felt) with the added feel of the vibration-free Control Core elastomer center. U.S. Patent #7626108



**UNI-LOCK BEATER ANGLE CAM**  
Grips the axle a full 360 degrees, allowing infinite beater angle adjustments. Floating Spring Pendulum design is perfectly centered on the clamp for full bearing movement and maximum smoothness.

# ELIMINATOR SOLO

## ELIMINATOR SOLO : BLACK

Delivering blinding speed and powerful performance, Eliminator Solo bass drum pedals put the fleet footed player in control with all the gliding velocity that made Pearl pedals revolutionary. These no nonsense, streamlined Eliminator models deliver singular, resistance free feel for effortless play and driving performance.

The Solo: Black pedal's even, slightly weighted feel delivers just the right amount of resistance without slowing your stroke - for increased power and less muscle fatigue.

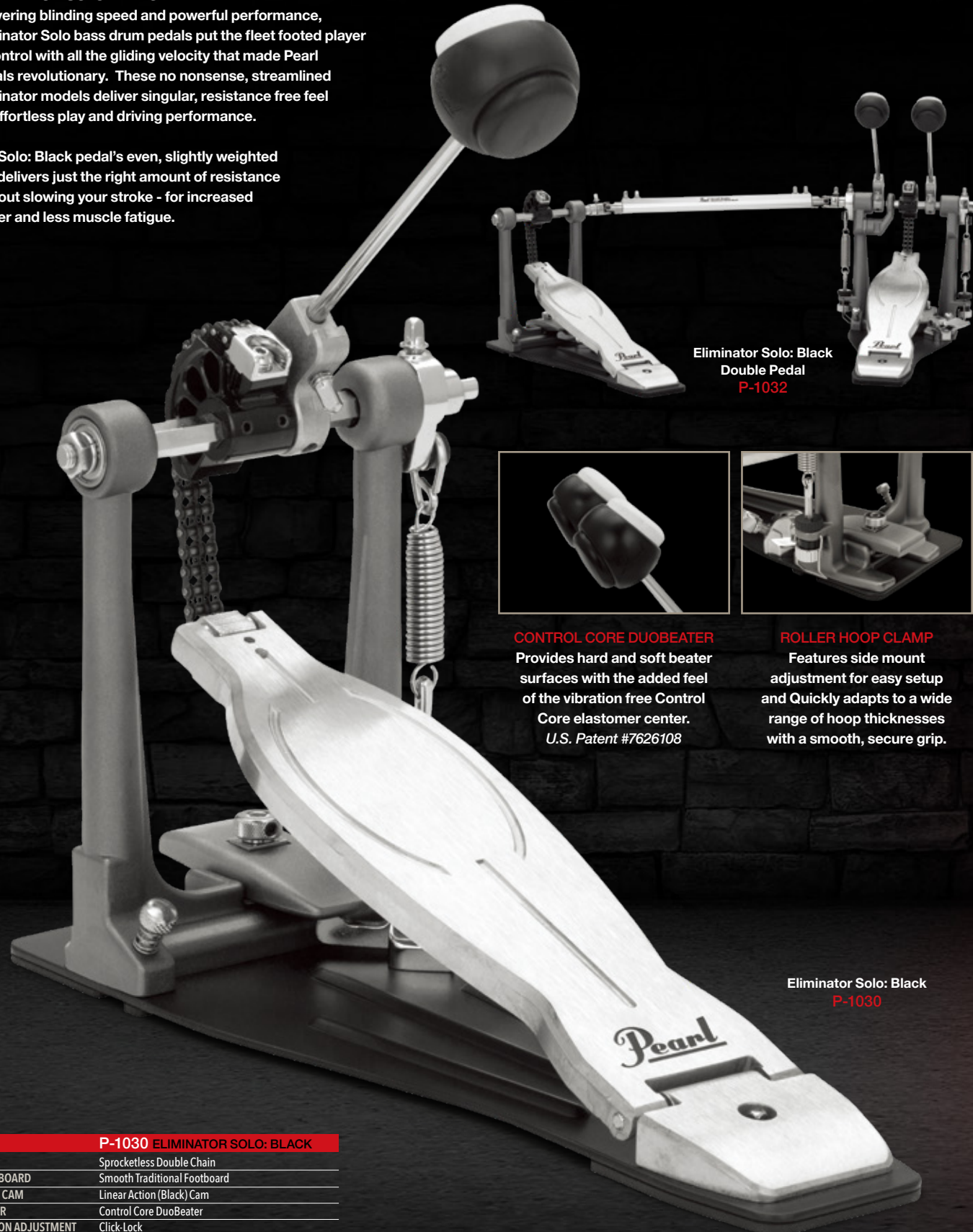

Eliminator Solo: Black Double Pedal P-1032

Eliminator Solo: Black P-1030



**CONTROL CORE DUOBEATER**  
Provides hard and soft beater surfaces with the added feel of the vibration free Control Core elastomer center.  
U.S. Patent #7626108

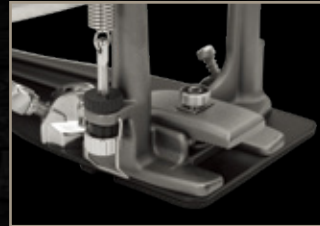

**ROLLER HOOP CLAMP**  
Features side mount adjustment for easy setup and Quickly adapts to a wide range of hoop thicknesses with a smooth, secure grip.

Singular Feel, Eliminator Speed, Priced to Perform. Fly Solo and Set Your Feet Free!

## ELIMINATOR SOLO : RED

Delivering accurate speed and focused performance, the Eliminator Solo: Red bass drum pedal delivers no-nonsense Eliminator feel for the technically decisive player.

Focusing the drive on the accurate feel of the Radical Progressive Action of Eliminator: Redline Red Cam, its shape allows the double chain to better match the motion of your foot. This means smooth movement at the bottom of the stroke with an accelerated PUSH at the top, and quick rebound for reactive doubles.



Eliminator Solo: Red Double Pedal P-1032R

Eliminator Solo: Red P-1030R



**CONTROL CORE QUADBEATER**  
Provides four beater surfaces (two hard plastic, two felt) with the added feel of the vibration-free Control Core elastomer center.  
U.S. Patent #7626108



**UNIVERSAL JOINT**  
All Eliminator Solo pedals come with Pearl's adjustable Universal Drive Joint, giving the secondary pedal the feel, power, and unrestrained feel of the main pedal.

P-1030 ELIMINATOR SOLO: BLACK	
Drive	Sprocketless Double Chain
FOOT BOARD	Smooth Traditional Footboard
DRIVE CAM	Linear Action (Black) Cam
BEATER	Control Core DuoBeater
TENSION ADJUSTMENT	Click-Lock
BEATER ANGLE	Uni-Lock Beater Angle Cam
POWERSHIFTER	Three Position
HOOP CLAMP	Roller Cam Hoop Clamp

P-1030R ELIMINATOR SOLO: RED	
Drive	Sprocketless Double Chain
FOOT BOARD	Smooth Traditional Footboard
DRIVE CAM	Radical Progressive Action (Red) Cam
BEATER	Control Core Quad Beater
TENSION ADJUSTMENT	Click-Lock
BEATER ANGLE	Uni-Lock Beater Angle Cam
POWERSHIFTER	Three Position
HOOP CLAMP	Roller Cam Hoop Clamp

# P-930 / P-932 PEDALS

Speed and Control for the Masses

## SUPER SMOOTH, EXTREMELY FAST!

Merging quick rebound response of our flagship Demon Drive with the finely-tuned control of our award-winning Eliminator models, the P930 bass drum pedal offers high end performance at a player accessible price. Its longboard playing deck delivers a lighter feel for increased speed, and offers advanced performance control and tunability with two rotor cam options. The ultimate pedal for fast feet on a budget.

P-930 BASS DRUM PEDAL	
Drive	Single Chain Drive
FOOT BOARD	Demon Style Long Board
DRIVE CAM	Perfect Circle Cam w/ Removable Eliminator Style Progressive Cam
BEATER	Control Core DuoBeater
TENSION ADJUSTMENT	Click-Lock
BEATER ANGLE	Infinite Beater Angle Adjustment
POWERSHIFTER	2 Position Powershifter Function
HOOP CLAMP	Adjustable Lever Clamp

P-932 DOUBLE BASS DRUM PEDAL	
Drive	Single Chain Drive
FOOT BOARD	Demon Style Long Board
DRIVE CAM	Perfect Circle Cam w/ Removable Eliminator Style Progressive Cam
BEATER	Control Core DuoBeater
TENSION ADJUSTMENT	Click-Lock
BEATER ANGLE	Infinite Beater Angle Adjustment
POWERSHIFTER	2 Position Powershifter Function
HOOP CLAMP	Adjustable Lever Clamp
UNIVERSAL JOINT	Length and Position Adjustable

Single Pedal Complete	P-930
Double Pedal Complete (right footed)	P-932
Double Pedal Conversion Kit (right footed)	P-931
Double Pedal Complete (left footed)	P-932L

### ORANGE PROGRESSIVE CAM

can be removed to reveal the Perfect Circle for further tunability to match your playing style.

### CONTROL CORE DUO BEATER

(U.S. Patent #7626108) utilizes an elastomer center to minimize vibration and features two unique playing surfaces (rounded felt and convex hard plastic surface) for quick-shifting tone and feel.

### POWERSHIFTER FUNCTION

(U.S. Patent #5574237) further tunes the power, feel, and leverage of the pedal by shifting the chain angle forward for lighter feel, or back for increased power.



The P-930 pedal is included as an upgrade in the 830 Series hardware pack and comes with Export drum sets.

CONTROL CORE DUO BEATER

BEATER HEIGHT ADJUSTMENT



Comes standard with Perfect Circle and removable Orange Progressive Cams, for fully tunable performance and increased control.

INTERCHANGEABLE CAM TECHNOLOGY

INFINITE BEATER ANGLE ADJUSTMENT



Single Pedal Complete P-930

2 POSITION POWERSHIFTER FUNCTION

CLICK-LOCK SPRING TENSION maintains perfect tension gig after gig. Set it and forget it. (U.S. Patent #7754953)



Double Pedal Complete P-932

Double the speed, power and control with the P-932 Double Pedal. Give your feet the gift of speed at a fraction of the cost of other "less innovative" pedals.

# P-920 / P-922 / P-830 / P-63 PEDALS

Speed, Power, and Value

## THE FAST TRACK TO BASS DRUMMING SPEED AND POWER

Fine-Tuned for a more refined playing experience, the P-920 bass drum pedal, featuring the patented Powershifter system (U.S. Patent #5574237), helps you modify your playing approach with an adjustable three position heel plate. Locking the plate in forward, middle, or aft positions changes the chain drive angle and delivers light, standard, or strong feel with fast, accurate beater action.

Single Pedal Complete P-920

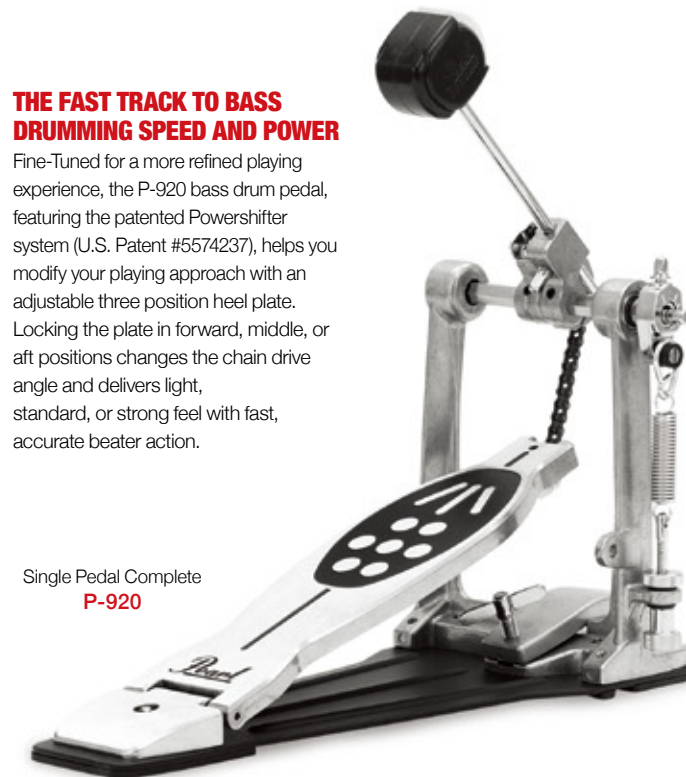

POWERSHIFTER FUNCTION



The Perfect Circle chain-drive cam

P-920	
Drive	Sprocketless Double Chain
FOOT BOARD	Standard Length
DRIVE CAM	Round/Linear Action
BEATER	DuoBeat Two-Surface (Hard Plastic/Felt.)
BEATER ANGLE	Infinite Beater Angle Adjustment

P-922	
Drive	Sprocketless Double Chain
FOOT BOARD	Standard Length
DRIVE CAM	Round/Linear Action
BEATER	DuoBeat Two-Surface (Hard Plastic/Felt.)
BEATER ANGLE	Infinite Beater Angle Adjustment

## P-922 DOUBLE BASS DRUM PEDAL

The Powershifter double pedal offers the same individual playing feel from both pedals when attached to a single kick drum. Each pedal is individually adjustable with the adjoining universal joint accurately capturing every stroke with exceptional accuracy. Each two surface DuoBeater is easily switchable and angle adjustable for personalized action and quick response.



Double Pedal Complete P-922

## P-830 DRUM PEDAL

Light in weight but not in features, the P-830's Demon-style longboard increases playing surface for maximum leverage and speed. Its fully adjustable beater angle, Perfect Circle single chain cam, and DuoBeat two-surface beater deliver customizable feel for the player on the move.

P-830	
Drive	Sprocketless Double Chain
FOOT BOARD	Long Board
DRIVE CAM	Round/Linear Action
BEATER	DuoBeat Two-Surface (Hard Plastic/Felt.)
BEATER ANGLE	Infinite Beater Angle Adjustment

Single Pedal Complete P-830



## P-530 DRUM PEDAL

With all the speed and function of a pro bass drum pedal at half the price, Pearl's P-530 Bass Drum Pedal features a dual chain and Linear Action cam drive for smooth, traditional pedal action and speed. The radius rod frame makes it highly portable for gigging, while features like a two surface DuoBeater and rotor tension axle clamp make it adaptable to virtually any feel or playing style.

P-530	
Drive	Sprocketless Double Chain
FOOT BOARD	Standard Length
DRIVE CAM	Round/Linear Action
BEATER	DuoBeat Two-Surface (Hard Plastic/Felt.)
BEATER ANGLE	Uni-Lock Beater Angle Cam

Single Pedal Complete P-530





# HI-HAT STANDS

Biggest Advancement In Time-Keeping Since The Wristwatch

Sharing many of the key characteristics of Pearl's Eliminator Redline bass drum pedals, 2050 Series Hi-Hat Stands deliver unparalleled versatility and customization in hi-hat pedal control. The world's-only hi-hat stand featuring the Interchangeable Cam System, 2050 Series stands' customizable options are designed to eliminate resistance, reduce fatigue, and increase performance.

*"Night in and night out, Pearl hardware keeps everything right where it should be, and without fail!"*  
- OKWA ANDREWS

BRIAN FRASIER-MOORE  
Justin Timberlake / Pink

OKWA ANDREWS  
Brian's Tech



**CLA-130**  
Closed Hi-Hat  
Bass Drum Hoop Mounted  
Side-to-Side,  
Forward/Back Adjustable  
Ultragrip Wingnut  
Spring Adjustable  
Cymbal Spread



**CLH-930**  
Closed Hi-Hat  
Uni-Lock Tilter  
Knurled Boom Arm  
UltraGrip Wing Nuts  
/ Wing Bolts



**CLH-70**  
Closed Hi-Hat  
Multi-Angle Quickset Clamp  
Gearless UniLock Tilter  
Ultragrip Wingnut  
Spring Adjustable Wash

Features Eliminator Solo traditional footboard, double braced swiveling tripod, and gigging weight tubing for touring professionals.

Features Eliminator Solo traditional footboard, single braced swiveling tripod, and reduced weight for gigging professionals.

Features an independent tripod positioned separately from the pedal frame, making it the only flat based hi-hat stand specifically for double pedals.

The RH-2050 Remote Hi-Hat's low-friction cable produces smooth, lag-free performance with the lightning-fast action of the PosiLink Twin Cam drive system. Fast, natural-feeling cymbal play is finally accessible virtually anywhere on the kit, or to facilitate multiple hi-hat system setups.

Pearl's Rapid Lock Super Grip's slip-proof clutch system features a patented 360° lock nut that provides vice-like clamping force for a super grip.



	RH-2050	H-2050	H-1050
Height Range	---	750 to 1030mm	700 - 960mm
Drive	PosiLink Twin Cam Drive System with Interchangeable Cams	PosiLink Twin Cam Drive System with Interchangeable Cams	Direct Pull Drive System
Footboard	Redline Reversible Traction Plate	Redline Reversible Traction Plate	Redline Reversible Traction Plate
Clutch	Rapid Lock Clutch (U.S. Patent #9355625)	Rapid Lock Clutch (U.S. Patent #9355625)	Rapid Lock Clutch (U.S. Patent #9355625)
Tension adjustment	Precision Spring Tension Dial	Precision Spring Tension Dial	Precision Spring Tension Dial
Leg Function	Swiveling Legs	Swiveling Legs	Swiveling Legs
Leg Tip	Spike/Rubber Tips	Spike/Rubber Tips (U.S. Patent #7371953)	Spike/Rubber Tips

	H-1030	H-1030S	H-930	H-830	H-150S
Height Range	760 - 940mm	760 - 940mm	760 - 940mm	610 - 910mm	745 - 865mm
Drive	Direct Pull Drive System	Direct Pull Drive System	Direct Pull Drive System	Direct Pull Drive System	Direct Pull Drive System
Footboard	Smooth Traditional Footboard	Smooth Traditional Footboard	Demon Style Long Board Footboard	Demon Style Long Board Footboard	Redline Reversible Traction Plate
Clutch	Standard Clutch	Standard Clutch	Standard Clutch	Standard Clutch	Standard Clutch
Tension adjustment	Precision Spring Tension Dial	Precision Spring Tension Dial	Precision Spring Tension Dial	---	Precision Spring Tension Dial
Leg Function	Swiveling Legs	Swiveling Legs	Swiveling Legs	Swiveling Legs	Swiveling Legs
Leg Tip	SureGrip Oversize Rubber Feet	---	SureGrip Oversize Rubber Feet	---	---



**INDEPENDENT TRACTION GRIPS**  
Features Pearl's exclusive reversible Traction Plate and individual traction grips, configurable to suit your individual taste.



**H-2050 PRECISION SPRING TENSION DIAL**  
Allows perfect tension control for fine-tuned response.



**H-1050 PEDAL HEIGHT ADJUSTMENT**  
The infinite footboard angle adjustment featured on the H-2050 and H-1050 allows precise height matching in multi-pedal setups.



**CLAMSHELL CLAMP**  
The H-2050, H-1050, H-1030, H-1030S, and H-930 Hi-Hat Stand uses beefy 1" tubing and clamshell clamps with built-in memory locks for superior rigidity.



**HA-130**  
Positions your hi-hat next to your bass pedal in double bass set-ups for effortless transitions between pedals.



**H-930 HI-HAT STAND**  
The H-930 Hi-Hat Stand features our Demon style longboard, double braced tripod w/ swivel function, and precision tension dial.



**H-830 HI-HAT STAND**  
The H-830 Hi-Hat Stand is standard equipment with our Export series and offers a monochromatic Demon Style longboard design and swivel tripod.



**H-150S\* FLAT-BASED SWIVELING HI-HAT**  
The H-150S independent tripod is positioned separately from the pedal frame making it the only flat-based hi-hat stand with swiveling legs.

# SNARE STANDS

No matter the gig or the drum, Pearl has a stand to accommodate both with security, high function, and chameleon-like diversity.

Every Snare Should Be So Lucky



S-1030



S-1030D



S-930

	S-1030	S-1030D	S-930
Height Range	480 - 700mm	310 - 520mm	470 - 670mm
Fit Snares	Adjustable Snare Basket: Fits Snares 10" - 16"	Adjustable Snare Basket: Fits Snares 10" - 16"	10" - 14"
Tilter	GyroLock Tilter: Infinite Angle Adjustability	GyroLock Tilter: Infinite Angle Adjustability	Uni-Lock Tilter
Arm Tips	Air Suspension Rubber Tips	Air Suspension Rubber Tips	Air Suspension Rubber Tips
Tripod	Trident Tripod	Trident Tripod	Double Braced Trident Style Tripod
Leg Tips	Oversize Super Grip Rubber Feet	Oversize Super Grip Rubber Feet	Super Grip Rubber Feet



**S-1030 SNARE STAND GYROLOCK**

Our premier S-1030 model features Pearl's 360 degree infinitely adjustable GyroLock tilter for ease-of-use and pinpoint positioning.



**S-1030 SNARE BASKET**

The Pearl S-1030 Snare Stand adjusts to fit virtually any size snare from 10" to 16". The Air Suspension rubber tips securely cradle your prized snares while allowing them to fully resonate.



**S-930D SNARE BASKET**

The S-930D Snare Stand is a shorter version of the S-930 Snare Stand, and is built to comfortably accommodate deeper snare drums.

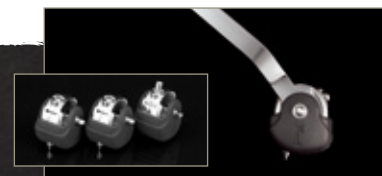

**SPIKED / RUBBER FEET** (Sold Separately)

Our CVT-300/3 Push Button Spiked/Rubber Feet come in pack of 3 to retrofit on any of our 1030 Series hardware for sure-footed performance on any terrain. (U.S. Patent #7371953)



S-930D

Drop basket for deeper snares



S-930S



S-830

Standard with Export Series drums, perfect for local gigging and easy transport

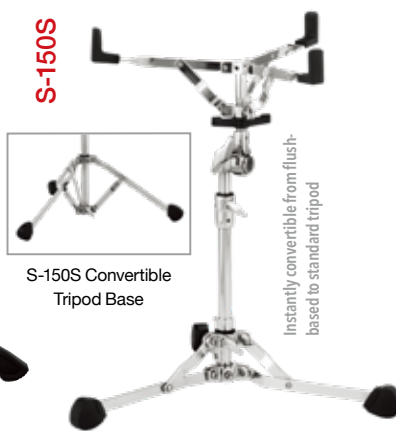

S-150S

S-150S Convertible Tripod Base

Instantly convertible from flush-based to standard tripod

	S-930D	S-930S	S-830	S-150S
Height Range	360 - 570mm	420 - 610mm	440 - 650mm	440 - 640mm
Fit Snares	10" - 14"	10" - 14"	13" - 14"	12" - 14"
Tilter	Uni-Lock Tilter	Uni-Lock Tilter	Uni-Lock Tilter	Gearless Uni-Lock Basket Tilter
Arm Tips	Air Suspension Rubber Tips	Air Suspension Rubber Tips	Rubber Grip	Rubber basket grips
Tripod	Double Braced Trident Style Tripod	Single Braced Trident Style Tripod	Double Braced Tripod	Stable Flat-Based Tripod
Leg Tips	Super Grip Rubber Feet	---	Super Grip Rubber Feet	Convertible Rubber Feet

# DRUM THRONES

Sound Ergonomics

**MULTI-CORE FOAM TECHNOLOGY:** Roadster thrones now feature multiple layers of varied density foam which combine for a better playing foundation and improved feel.



D-3500BR



D-3500



D-1500TGL



D-1500RGL

	D-3500BR	D-3500	D-1500TGL	D-1500RGL
Height Range	495-665mm	495-665mm	495-695mm	495-695mm
Seat	Saddle-Style, Multi-Core Foam Cushion	Saddle-Style, Multi-Core Foam Cushion	15" Trilateral Multi-Core Foam Cushion Option of a Saddle or Round top feel	15" Round Multi-Core Foam Cushion
Legs	Double Legs	Double Legs	Lightweight Aluminum Struts	Lightweight Aluminum Struts
StopLock	Lock/Spin System: Reversible StopLock allows cushion to be secured in place or free spinning depending on preference	Lock/Spin Reversible StopLock System		
Notes	Detachable Backrest Mounts via Single Knob	Accepts Optional Backrest		Accepts Optional Backrest



D-1500SP



D-1500



D-1500S



DTBR-1535

	D-1500SP	D-1500	D-1500S	DTBR-1535
Height Range	525 - 630mm	495 - 665mm	445 - 615mm	
Seat	15" Vented Round Seat Multi-Core Foam Donut Cushion	15" Vented Round Seat Multi-Core Foam Donut Cushion	15" Vented Round Seat Multi-Core Foam Donut Cushion	12.5" x 7" Optional Backrest
Legs	Double Braced Legs	Double Braced Legs	Double Braced Legs	Formfitting and Breathable Removable Dual Axis Adjustability
StopLock	Lock/Spin Reversible StopLock System	Lock/Spin Reversible StopLock System	Lock/Spin Reversible StopLock System	
Notes	Accepts Optional Backrest Built-In Shock Absorber Post w/ Adjustable Spring Tension	Accepts Optional Backrest	Accepts Optional Backrest	



D-930



D-790



D-730S



D-50

	D-930	D-790	D-730S	D-50
Height Range	470 - 660mm	430 - 650mm	405 - 605mm	495 - 620mm
Seat	Round Vinyl Cushion	Round Vinyl Cushion	Round Vinyl Cushion	Round Vinyl Cushion
Legs	Double Braced Legs	Double Braced Legs	Single Braced Tripod	Double Braced Tripod

# CYMBAL STANDS

Welcome to Boom Town

## FOR EVERY CYMBAL, THERE IS A PLACE.

Advancing Drum Hardware for Serious Working Drummers since 1946. Through constant setup, teardown, performance, practice, and transport, Pearl has you covered with cymbal stand solutions that are ready to endure constant abuse and keep going.

Pearl hardware is literally the only hardware that you'll ever have to buy and it's all backed by their incredible lifetime warranty!

- TRACY BROUSSARD -

The most technically advanced boom stand ever devised. Perfect for studio or live applications.



	BC-2030	B-1030C	B-1030	BC-930
Type	Boom	Curved Boom	Boom	Boom/Straight
Height Range	800 - 2150mm	820 - 1900mm	820 - 1900mm	830 - 1800mm
Nut	WingLoc	WingLoc	WingLoc	Plastic Wingnut
Washer	Reversible Form / Felt Washer	Reversible Form / Felt Washer	Reversible Form / Felt Washer	Felt Washer
Cymbal Cup	Reversible Cup Washer w/ O-ring	Reversible Cup Washer w/ O-ring	Reversible Cup Washer w/ O-ring	Plastic Cymbal Cup
Tilter	GyroLock Tilter	GyroLock Tilter	GyroLock Tilter	Uni-Lock Tilter
Pipe Joint	Clamshell Clamp	Clamshell Clamp	Clamshell Clamp	Clamshell Clamp
Legs(Tripod)	Trident Tripod / Double Braced Legs	Trident Tripod / Double Braced Legs	Trident Tripod / Double Braced Legs	Trident Style Tripod / Double Braced Leg
Pipe diameter of stand	28.6/22.2/15.9mm	28.6/22.2/15.9mm	28.6/22.2/15.9mm	28.6/22.2/15.9mm

Reduced weight for easy gigging transport.

Offers lighter weight with advanced appointment designs.

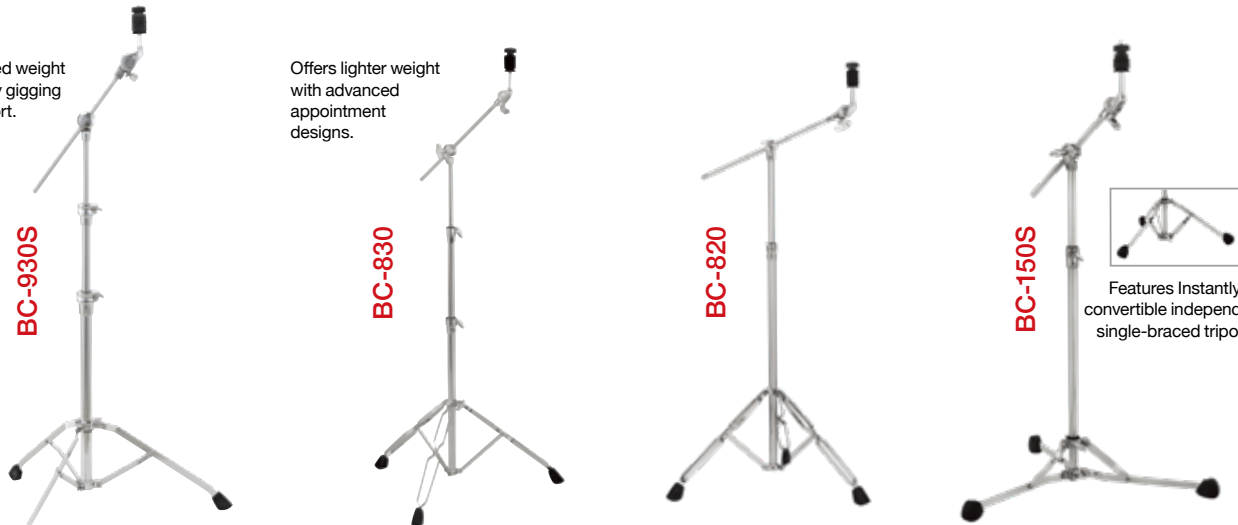

	BC-930S	BC-830	BC-820	BC-150S
Type	Boom/Straight	Boom/Straight	Boom/Straight	Boom/Straight
Height Range	780 - 1800mm	780 - 1480mm	900 - 1740mm	780 - 1300mm
Nut	Plastic Wingnut	Plastic Wingnut	Plastic Wingnut	Plastic Wingnut
Washer	Felt Washer	Felt Washer	Felt Washer	Reversible Felt/Foam Washer
Cymbal Cup	Plastic Cymbal Cup	Plastic Cymbal Cup	Plastic Cymbal Cup	Plastic Cymbal Cup
Tilter	Uni-Lock Tilter	Uni-Lock Tilter	Uni-Lock Tilter	Uni-Lock Tilter
Pipe Joint	Clamshell Clamp	Nylon Bushing Joint	Nylon Bushing Joint	Nylon Bushing Joint
Legs(Tripod)	Trident Style Single Braced Legs	Double Braced Legs	Double Braced Legs	Single Braced Tripod
Pipe diameter of stand	28.6/22.2/15.9mm	25.4/22.2/15.9mm	22.2mm/15.9mm	19.1 / 15.9 mm

Solid. Stable. Professional.

Exceptional stability for gigging and touring.

Built for rigid support and light transport.

Offers lighter weight with advanced appointment designs.

Features Instantly convertible independent single-braced tripod.



	C-1030	C-930	C-930S	C-830	C-150S
Type	Straight	Straight	Straight	Straight	Straight
Height Range	770 - 1530mm	760 - 1500mm	780 - 1480mm	720 - 1480mm	670 - 1350mm
Nut	WingLoc	Plastic Wingnut	Plastic Wingnut	Plastic Wingnut	Plastic Wingnut
Washer	Reversible Form / Felt Washer	Felt Washer	Felt Washer	Felt Washer	Reversible Felt/Foam Washer
Cymbal Cup	Reversible Cup Washer w/ O-ring	Plastic Cymbal Cup	Plastic Cymbal Cup	Plastic Cymbal Cup	Plastic Cymbal Cup
Tilter	GyroLock Tilter	Uni-Lock Tilter	Uni-Lock Tilter	Uni-Lock Tilter	Uni-Lock Tilter
Pipe Joint	Clamshell Clamp	Clamshell Clamp	Clamshell Clamp	Nylon Bushing Joint	Nylon Bushing Joint
Legs(Tripod)	Trident Tripod / Double Braced Legs	Trident Style	Trident Style	Double Braced Legs	Single Braced Tripod
Pipe diameter of stand	28.6/22.2/15.9mm	28.6/22.2/15.9mm	28.6/22.2/15.9mm	25.4/22.2/15.9mm	19.1 / 15.9 / 12.7mm



**REVERSIBLE FELT / FOAM CYMBAL WASHERS** allow four-way control of cymbal "ring" by mixing and matching the "hard" and "soft" surfaces of the washers.



**THE TRIDENT TRIPOD** uses a full 360° of clamping force via the hinged collar. The inner tube rests in a nylon bushing to prevent metal to metal contact. Heavy duty legs feature lateral bracing for superior ultra quiet rigidity.



**REVERSIBLE CUP WASHER w/ O-RING** (U.S. Patent #6940006) Specially designed to "float" normally or "lock" to prevent noise during recording.

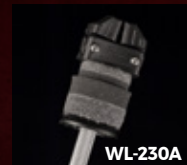

**WINGLOC**

Quick Release Wing Nut (U.S. Patent #6884015) Secure, adjustable, spring loaded cymbal nuts for quick set up and tear down.



**NODAL POINT MARKINGS**

Pearl's BC-2030 features markings on the telescopic tubes that allow cymbals to achieve better clarity and sustain when the tubes are positioned at their respective Nodal Points. (U.S. Patent #9070348)



**GYROLOCK TILTERS**

are infinitely adjustable and provide 360 degree range of motion for precise positioning with one-step convenience.

# ICON RACK SYSTEM

The Original Drum Rack, Expanded



**RACKS** Preconfigured single and three-sided rack packages with rotating support feet.



**MASTERWORKS SERIES STUDIO SHELL RECIPE**  
in Gloss Natural Artisan Sycamore with Ebony inlay & Black Nickel Hardware

**MASTERWORKS SERIES with ICON RACK & e/MERGE**  
in Black Sparkle Burst to Granite Sparkle & Black Nickel Hardware



**3-Sided Rack**  
(\*also available DR-008 Expansion Bar)  
**DR-80**

Developed in 1983 with legendary Toto drummer Jeff Porcaro, Pearl's original DR1 Drum Rack was the first freestanding, frame based drum support system available.

Now, Pearl expands the **ICON** (short for Independent **CON**trol) Rack system with a fresh selection of upgrades and high function mounting options.

DR-80	
<b>SUMMARY</b>	3-Sided Rack
<b>RAILS</b>	Black Painted Steel 38.1mm x 910mm
<b>PIPES</b>	Black Painted Steel 38.1mm x 705mm
<b>RAIL CLAMPS</b>	PC-8 (x4)



**Three-Sided Drum Rack, Straight**  
(w/ PCX-100X4 & PCL-100X2)  
**DR-513**

DR-513	
<b>SUMMARY</b>	Three-Sided Drum Rack, Straight
<b>RAILS</b>	Aluminum, 40mm Square
<b>PIPES</b>	Steel 38.1mm x 865mm
<b>RAIL CLAMPS</b>	PCX-100 (x4)
<b>PIPE CLAMPS</b>	PCL-100 (x2)
<b>SUPPORT FOOT</b>	38.1mm x 475mm (P-38475TA x4)
<b>USABLE RAIL AREA</b>	915mm (965mm From Center of Right to Left Clamp)



**Three-Sided Drum Rack, Curved**  
(w/ PCX-100X4 & PCL-100X2)  
**DR-513C**

DR-513C	
<b>SUMMARY</b>	Three-Sided Drum Rack, Curved
<b>RAILS</b>	Aluminum, 40mm Square
<b>PIPES</b>	Steel 38.1mm x 865mm
<b>RAIL CLAMPS</b>	PCX-100 (x4)
<b>PIPE CLAMPS</b>	PCL-100 (x2)
<b>SUPPORT FOOT</b>	38.1mm x 475mm (P-38475TA x4)
<b>USABLE RAIL AREA</b>	915mm (965mm From Center of Right to Left Clamp)



**Single Drum Rack, Straight**  
(w/ PCX-100X2 & PCL-100X2)  
**DR-511**

DR-511	
<b>SUMMARY</b>	Single Drum Rack, Straight
<b>RAILS</b>	Anodized Aluminum Square Bar 40mm x 915mm
<b>PIPES</b>	Steel 38.1mm Diameter, 865mm Height
<b>RAIL CLAMPS</b>	PCX-100 (x2)
<b>PIPE CLAMPS</b>	PCL-100 (x2)
<b>SUPPORT FOOT</b>	38.1mm x 475mm (P-38475TA x2)
<b>USABLE RAIL AREA</b>	915mm (965mm From Center of Right to Left Clamp)



**Single Drum Rack, Curved**  
(w/ PCX-100X2 & PCL-100X2)  
**DR-511C**

DR-511C	
<b>SUMMARY</b>	Single Drum Rack, Curved
<b>RAILS</b>	Anodized Aluminum Square Bar 40mm x 915mm
<b>PIPES</b>	Steel 38.1mm Diameter, 865mm Height
<b>RAIL CLAMPS</b>	PCX-100 (x2)
<b>PIPE CLAMPS</b>	PCL-100 (x2)
<b>SUPPORT FOOT</b>	38.1mm x 475mm (P-38475TA x2)
<b>USABLE RAIL AREA</b>	1118mm (1168mm From Center of Right to Left Clamp)



**Straight Drum Rack Expansion Bar w/ Support Leg**  
**DR-511E**

DR-511E	
<b>SUMMARY</b>	Straight Drum Rack Expansion Bar w/ Support Leg
<b>RAILS</b>	Anodized Aluminum Square Bar 40mm x 915mm
<b>PIPES</b>	Steel 38.1mm x 865mm
<b>SUPPORT FOOT</b>	38.1mm x 475mm (P38475TA x1)
<b>USABLE RAIL AREA</b>	915mm (965mm From Center of Right to Left Clamp)



**Curved Drum Rack Expansion Bar w/ Support Leg**  
**DR-511CE**

DR-511CE	
<b>SUMMARY</b>	Curved Drum Rack Expansion Bar w/ Support Leg
<b>RAILS</b>	Anodized Aluminum Square Bar 40mm x 915mm
<b>PIPES</b>	Steel 38.1mm x 865mm
<b>SUPPORT FOOT</b>	38.1mm x 475mm (P38475TA x1)
<b>USABLE RAIL AREA</b>	1118mm (1168mm From Center of Right to Left Clamp)



**Drum Rack Moveable w/Support T-Leg**  
**DR-110T**

DR-110T	
<b>SUMMARY</b>	Drum Rack Moveable Support T-Leg
<b>RAILS</b>	---
<b>PIPES</b>	---
<b>SUPPORT FOOT</b>	965mm x 64mm Round Chrome w/ P38475TA x1
<b>USABLE RAIL AREA</b>	---

# RACK ACCESSORIES

An Industry Icon - The Professional's Choice

## ICON RACK RECIPES

Check out Pearl's ICON Rack Recipe videos at [www.pearlrackrecipes.com](http://www.pearlrackrecipes.com) for step-by-step instructions on how to get the most from existing and available Pearl Rack parts.

## MOUNTING CLAMPS

Developed for the slip resistant ICON square rack rail and round support pipe. Each dramatically increases the level of setup flexibility and function variety.



**Expandable Pipe Clamp**  
Fits All Icon Rack Leg Posts  
**PCL-100**

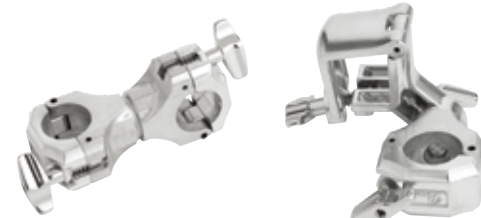

**Dual Pipe Clamp**  
**PCR-100**

**Pipe To Rail Clamp**  
**PCR-200**



**Pipe To Rail Clamp**  
**PCR-200L**



**Rotating Pipe Accessory Clamp**  
**PCR-50X**



**Pipe Accessory Clamp**  
**PCR-50L**



**Rotating Dual Pipe Clamp**  
**PCR-50R**



**Curved Rack Rail Short w/ Clamp**  
**AL-86AC**



**Curved Rack Rail Medium w/ End Caps**  
**AL-103A**



**Icon Support Foot w/ TLJ200 T-Clamp**  
**P-38475TA**



**Icon Rail Accessory Clamp w/ Adjustable Jaw**  
**PCX-100**



**Icon Rotating Pipe Clamp w/ Adjustable Jaw**  
**PCX-200**



**Extended Rotating Rail Accessory Clamp**  
**PCX-300**



**Pipe Clamp**  
Fits 7/8" tubes, for DR80  
**PC-8**



**Icon 6" Mini-Expansion Bar**  
**RJ-50**



**Pipe Joint**  
**RJ-100**



**ADP20**  
2 Clamps  
Fits 5/8" to 1-1/8"  
**ADP-20**

**AX25**  
2 Revolving Clamps  
Fits 1/2" to 1-1/8"  
**AX-25**

**AX25L**  
2 Revolving Clamps  
Fits 1/2" to 1-1/8"  
**AX-25L**

**AX28**  
In-Line & Revolving Clamps  
Fits 5/8" to 1-1/8" & 1/2" to 1-1/4"  
**AX-28**

**ADP30**  
3 Adjustable Clamps  
Fits 3/8" to 1-1/4"  
**ADP-30**

# TOM STANDS / ARMS

Positioning Possibilities Never Before Attainable



**T-1035**

**T-1035L**

**T-935**

**TC-1035B**

**TC-1035BL**

**TC-935**



**CHB-75CA**



**CHB-75LB**



**CH-1030B**



**CH-930**



**CH-830**



**TH-1030**

**TH-1030S**

**TH-1030I**

**THL-1030**  
U.S. Patent Pending

**THL-1030S**  
U.S. Patent Pending



**TH-900S**

**TH-900I**

**TH-88S**

**TH-88I**

**TH-70S**

**TH-70I**



**UX-80S UX-80**

**Tube Height Extender**  
**TX-100**

Features rotating infinitely adjustable clamps for multiple uses.

**Tube Extender for 1" Pipe**  
**TX-125**

**Tube Extender for 1" Pipe**  
**TX-125**

Accepts 1" dia. tubes. Ideal for extending travel conga stands.



**Chrome Multi Bass Drum Legs**  
**PM-BDL3/C**

Multi-Bass Drum Legs allow any bass drum to be played horizontally. Height and tilt adjustable.



**Bass Drum Mount Cymbal Holder**  
**CHB-830**

Mounts directly to the bass drum.

# PEARL PERCUSSION ARTISTS

VIEW ALL THE PEARL ARTISTS AT:



**AARON DRAPER**  
John Mayer / Eminem / Adele

**ALAIN PEREZ**  
Alain Perez

**ANDY FARAG**  
Umphreys McGee

**ARCHIE PENA**  
Shakira

**BOBBY ALLENDE**  
Tito Nieves

**BRETT BAKER**  
Rihanna / Jay-Z



**CAMILO QUINONES**  
El Dusty

**CARLITO SOTO**  
Willie Colon

**CARLITOS PADRON**  
Rumberos Del Callejon

**CESAR ESPINOZA**  
Orchestra Tobaco Y Ron

**CHRISTIAN PEPIN**  
Independent

**COLIN DOUGLAS**  
Aerosmith



**CRYSTAL VARGAS**  
Independent

**DIMAS SANCHEZ**  
Fusion Beat / Trilogy Latin Jazz

**DOMINIQUE THOMAS**  
John Legend / Jill Scott

**EMRAH KOTAN**  
Independent

**ETTIENNE FUENTES**  
Independent

**HORACIO HERNANDEZ**  
Independent



**JESSIE CARABALLO**  
Marc Anthony

**JESUS DIAZ**  
Independent

**JOSE ROSA**  
Independent

**LALO DAVILA**  
MTSU

**MARC QUIÑONES**  
The Doobie Brothers

**MARCO "ITO" ARGUINZONI**  
Independent



**MARVIN DIZ**  
Independent

**OG**  
Slightly Stoopid

**OMAR LEDEZMA**  
Independent

**PAPO PEPIN**  
N.Y. Conga Legend

**RAFA PERIERA**  
Janelle Monae

**RAVI JAKHOTIA**  
Ravi Drum

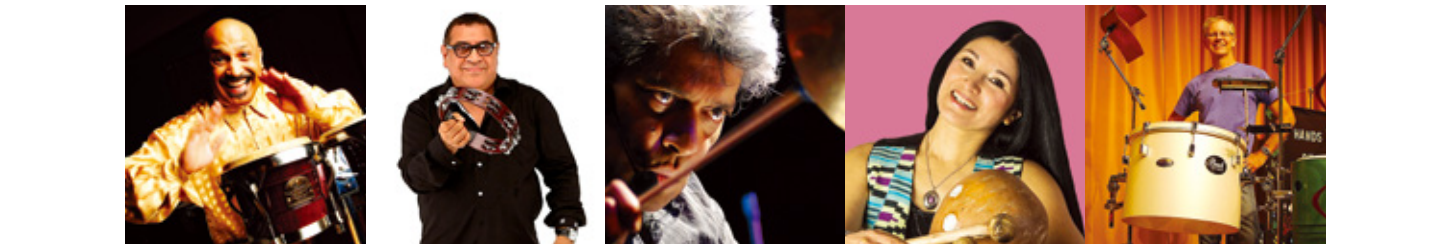

**ROLANDO MORALES MATOS**  
The Lion King / Curtis Institute

**SAMMY FIGUEROA**  
Master Percussionist

**TRILOK GURTU**  
Independent

**VALERIE DEE NARANJO**  
The Lion King / Saturday Night Live

**ZIG WAJLER**  
Hands-On With Zig

# SIGNATURE SERIES

The Pros Play Pearl!

## BOBBY ALLENDE

Bobby Allende is a mainstay in the New York Latin Music Scene and he demands the best from his drums, that's why he plays Pearl. His Signature drums are fiberglass with no seams to inhibit vibration which allow the drums to resonate freely for the full, rich sound that Bobby is famous for. The congas are 28 inches tall, fitting the traditional seated player perfectly while adding extra width to the base for added projection and stability. A matching set of bongos is also available.



#617 Confetti  
Signature Fiberglass  
Congas and Bongos



**SHELL** Seamless Fiberglass  
**HEADS** Remo Fiberskyn3  
**RIMS** Low-Rider Contour Crown  
**HARDWARE** Brushed Steel  
**FINISH** #617 Confetti  
**BONGOS** PBF-300DXBA  
**OPTIONAL BAGS** PSC-110CG 11" Quinto Conga Bag  
PSC-117CGW 11.75" Conga Bag  
PSC-125CG 12.5" Tumba Conga Bag

The Bobby Allende congas and bongos feature Remo Fiberskyn 3 heads for tuning stability and Pearl's Low-Rider crowns with a radical sloping edge that practically disappears under your hands for comfort you have to experience to believe.

If you demand excellence like Bobby, check out his Signature Fiberglass Congas and Bongos.

**CONGAS**  
PCF-110DXBA 11" QUINTO  
PCF-117DXBA 11.75" CONGA  
PCF-125DXBA 12.5" TUMBA

**BONGOS**  
PBF-300DXBA 7" & 8.5"

## JESUS DIAZ

Cuban born Jesus Diaz is one of the most in demand percussionists and vocalists on the scene today. His active schedule provided the feature set for his signature series of congas and bongos. Designed for the seated player the Thai Oak drums measure 30" tall and from the Quinto to Tumba feature added girth to the belly of the drum. Seated conga players typically have to tilt the drum to achieve the desired projection, but the Jesus Diaz drums feature a 4" port on the front of the drum that is strategically positioned to deliver the maximum base frequency while the drum remains flat on the floor.



PHOTO: LISA KEATIN



**SHELL** Thai Oak  
**HEADS** Buffalo Skin  
**RIMS** Low-Rider Contour Crown  
**HARDWARE** Quick Release Lugs  
Brushed Steel Finish  
**FINISH** #580 Brushed Platinum  
**BONGOS** PBW-300DXJD  
**OPTIONAL BAGS** PSC-110CG 11" Quinto Conga Bag  
PSC-117CGW 11.75" Conga Bag  
PSC-125CG 12.5" Tumba Conga Bag



#580 Brushed Platinum  
Natural Buffalo Skin Heads

The drums also feature a newly designed Quick Release lug that is slotted to allow removal of the tension rod without fully removing the nut. Player comfort was also an important ingredient in the design of the hoop. A new ergonomically friendly design reduces the impact to your hands while an internal ring centers the natural buffalo skin heads for accurate placement.

**CONGAS**  
PCW-110DXPJD 11" QUINTO  
PCW-117DXPJD 11.75" CONGA  
PCW-125DXPJD 12.5" TUMBA

**BONGOS**  
PBW-300DXJD 7" & 8.5"

# CONGAS & BONGOS

Tools of the Trade

## ELITE SERIES

### ELITE WOOD-FIBER CONGAS

**PWFC-110DX648** - 11" QUINTO  
**PWFC-117DX648** - 11.75" CONGA  
**PWFC-125DX648** - 12.5" TUMBA

SHELL Blended, Thai Oak over Fiberglass  
 HEADS Natural Cow Skin  
 RIMS Contour Crown  
 HARDWARE Brushed Steel  
 FINISH #648 Dark Chocolate

### ELITE WOOD-FIBER BONGOS

**PWFB-100DX648** - 7" & 8.5"



### ELITE OAK CONGAS

**PCW-110DX510** - 11" QUINTO  
**PCW-117DX510** - 11.75" CONGA  
**PCW-125DX510** - 12.5" TUMBA

SHELL 100% Thai Oak  
 HEADS Premium Natural Cow Skin  
 RIMS Contour Crown  
 HARDWARE Brushed Steel  
 FINISH #510 Caramel Brown

### ELITE OAK BONGOS

**PBW-300DX510** - 7" & 9"



### ELITE FIBERGLASS CONGAS

**PCF-110DXA** - 11" QUINTO  
**PCF-117DXA** - 11.75" CONGA  
**PCF-125DXA** - 12.5" TUMBA

SHELL Fiberglass  
 HEADS Premium Natural Cow Hide  
 RIMS Contour Crown  
 HARDWARE Brushed Steel  
 FINISH #641 Blue Sparkle Burst

### ELITE OAK BONGOS

**PBF-300DXA** - 7" & 9"

### ELITE OAK CONGAS

**PCW-110DX504** - 11" QUINTO  
**PCW-117DX504** - 11.75" CONGA  
**PCW-125DX504** - 12.5" TUMBA

SHELL 100% Thai Oak  
 HEADS Premium Natural Cow Skin  
 RIMS Contour Crown  
 HARDWARE Chrome  
 FINISH #504 Mocha Burst

### ELITE OAK BONGOS

**PBW-300DX504** - 7" & 9"



### ELITE OAK CONGAS

**PCW-110DX506** - 11" QUINTO  
**PCW-117DX506** - 11.75" CONGA  
**PCW-125DX506** - 12.5" TUMBA

SHELL 100% Thai Oak  
 HEADS Premium Natural Cow Skin  
 RIMS Contour Crown  
 HARDWARE Chrome  
 FINISH #506 Merlot Burst

### ELITE OAK BONGOS

**PBW-300DX506** - 7" & 9"



Also available in #532 Cherry Eucalyptus

### ELITE OAK CONGAS

**PCW-110DXG** - 11" QUINTO  
**PCW-117DXG** - 11.75" CONGA  
**PCW-125DXG** - 12.5" TUMBA

SHELL 100% Thai Oak  
 HEADS Premium Natural Cow Skin  
 RIMS Contour Crown  
 HARDWARE Gold  
 FINISH #535 Satin Black

### ELITE OAK BONGOS

**PBW-300DXG** - 7" & 9"

## HAVANA SERIES

**HAVANA CONGAS**  
**PCF-110HV** - 11" QUINTO

**PCF-117HV** - 11.75" CONGA

**PCF-125HV** - 12.5" TUMBA

**HAVANA BONGOS**  
**PBF-300HV** - 7" & 8.5"



The wide belly shape of these high end, fiberglass drums produce deeper low tones and greater volume.

SHELL Fiberglass  
 HEADS Natural Cow Skin  
 RIMS Contour Crown  
 HARDWARE Chrome  
 FINISH #644 Liquid Gold

SHELL Fiberglass  
 HEADS Natural Cow Skin  
 RIMS Contour Crown  
 HARDWARE Chrome  
 FINISH #187 Silver White Swirl

SHELL Fiberglass  
 HEADS Natural Cow Skin  
 RIMS Contour Crown  
 HARDWARE Chrome  
 FINISH #651 Red Tiger Stripe

## PRIMERO PRO

### PRIMERO PRO FIBERGLASS



11.75" & 12.5" Conga Set #628 Blue Marble  
 Shown with matching bongos  
**PFC-302DX**



10" & 11" Conga Set  
 #621 Wine Red Marble  
**PFC-202DX**



7" & 8.5" Bongos  
 #523 Carbon Vapor  
**PWB-100DX**

11.75" & 12.5" Congas  
 #523 Carbon Vapor  
**PWC-302DX**

PFC-302DX #626 Gold Marble



Designed with professional features at an affordable price. Our expanded range of sizes offers 10" & 11" and 11.75" & 12.5" sets in both Thai Oak and Fiberglass with matching bongos.

### PRIMERO PRO FIBERGLASS

**PFC-302DX**  
 (11.75" & 12.5" Conga Set)  
**PFC-202DX**  
 (10" & 11" Conga Set)

Offer added durability of fiberglass and are louder drums with a crisper sound than wood.

SHELL Fiberglass  
 HEADS Buffalo Skin  
 RIMS Contour Crown  
 HARDWARE Brushed Steel  
 FINISH #621 Wine Red Marble  
 #626 Gold Marble  
 #628 Blue Marble

### PRIMERO PRO OAK

**PWC-302DX**  
 (11.75" & 12.5" Conga Set)  
**PWC-202DX**  
 (10" & 11" Conga Set)

Primero Pro wood congas are made with Thai Oak and produce a warm, rich tone.

SHELL Thai Oak  
 HEADS Buffalo Skin  
 RIMS Contour Crown  
 HARDWARE Brushed Steel  
 FINISH #511 Natural  
 #521 Midnight Fade  
 #523 Carbon Vapor

## PRIMERO



10" & 11" Conga Set w/ PC300 Stand  
**PFC-203**

Primero Series congas and bongos are available with fiberglass shells and in packages that include a double stand (PC-300W) or without stands.



10" & 11" Conga Set  
**PFC-202**

SHELL Fiberglass  
 HEADS Buffalo Skin  
 RIMS Contour Crown  
 HARDWARE Black Powder Coat  
 FINISH #602 Bistre Black

## FIELD PERCUSSION



Weather resistant fiberglass body that delivers a thunderous low-end tone. Remo Nuskyn heads.

10" & 11" Congas  
 #649 Textured Black  
**PFC-202EDU**

## CONGA RESO-PLATE



Designed for the seated conga player, Pearl's Reso-Plate will give you that hard surface desired for maximum resonance. Configured with a cutout handle, the plates can also easily be placed on top of your drums for extra protection when packed in your conga case.

Conga Reso-Plates  
**PRP-140**

# TRAVEL

## Congas, Bongos, & Timbales



Where can you take the Pearl Travel Congas and Bongos? The answer is anywhere you can take traditional drums but without any of the hassle. The Travel Congas feature a 3.5" deep wood shell with stave construction and Remo Symmetry heads. Available in three sizes: 11" x 3.5", 11.75" x 3.5" and 12.5" x 3.5" each with five precision Allen bolts. The 7" and 8.5" Travel Bongos feature 3.5" Thai Oak shells with Remo Fiberskyn heads and three point tuning. The Travel Congas and Bongos include a foam-handle tuning wrench.

### CONGAS



11.75" Travel Conga  
#510 Caramel Brown  
PTC-1175N

12.5" Travel Conga  
#510 Caramel Brown  
PTC-1250N

11" Travel Conga  
#510 Caramel Brown  
PTC-1100N



Travel Conga Bag  
PSC-1175TC



Travel Bongos Bag  
PSC-785TB

The optional Travel Conga Stand works with all three size drums and features a tension lever mounting system that locks the drum into place. The wide based, double braced legs provide a solid foundation for your drum and prevents the stand from moving during performance.

### BONGOS



Travel Bongos  
#510 Caramel Brown  
PTB-785



Travel Conga Stand  
w/ Carrying Bag  
PC-800TC

Travel Bongos Stand  
PC-800TB  
PC-800TBS (Short)

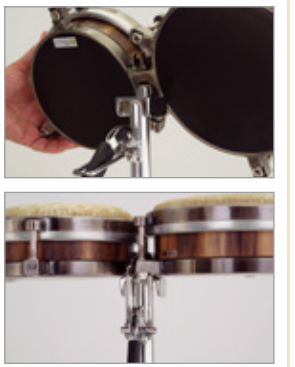

### TIMBALES



Travel Timbales 14" & 15"  
with Stand\*  
PTTM-1415

\*Bag sold separately



The Pearl Travel Timbales feature 14" and 15" steel shells that are professional size in diameter but only 4" deep.



The drums are connected by a hinge that marries them to the Quick Release stand. The custom hinge allows the drums to be folded together into the size of one standard depth timbale for easy storage and transportation.



The Travel Timbales come with a single braced stand that includes an 11.25" adjustable accessory post with 6 positions that allow cowbells and blocks to be placed the perfect distance from the player.



The steel shells feature a black lacquer finish and USA Remo clear Ambassadors heads for a truly professional sounding instrument. A soft carrying case for the stand is also included (sold separately).

# TIMBALES



MARC QUIÑONES  
Doobie Brothers

### MARC QUIÑONES SIGNATURE TIMBALES



Marc Quiñones Signature Timbales  
14"x7" / 15"x7" Steel  
w/ PT900 Tilting Stand  
and PBL30 Clave Block  
(Cowbell Not Included)  
ETE-1415MQ



Primero  
13"x7" Steel Timbale  
w/ PPS-36 Mount  
PTE-1336



Flat Timbale w/ I.S.S.  
13"x3" Steel  
PTE-3131



Tilting Timbale  
Stand (Short)  
Height Range  
26.5" to 36.5"  
PT-900WS



Primero Timbales  
13"x6.5" / 14"x6.5" Steel  
w/ PT-900 Tilting Stand  
(Stands & Cowbell Included)  
PTS-5134



Primero Pro Timbales  
14"x7" / 15"x7" Steel  
w/ PT900 Tilting Stand  
(Sticks Included,  
Cowbell Not Included)  
PTE-1415DX

# COWBELLS

Pearl and Grammy Award winning artist Horacio Hernández have developed the ultimate family of cowbells. The HH-4XH bell features a quick release system that allows the bell to lift easily off of its mount for hand held playing.

HORACIO HERNÁNDEZ  
Latin Legend



### HORACIO HERNÁNDEZ SIGNATURE COWBELLS



Marybell  
HH-5

Hand-Held Campana  
Quick Release  
HH-4XH

Isabell  
Mambo Bell  
HH-4

Chabella  
HH-3

Clabell  
HH-2

Bella  
HH-1

### AGOGO & TRIBELLS



Tri-Bells  
PTB-30

Hand-Held  
Agogo  
ECB-22

Mounted  
Agogo  
ECB-23

### NEW YORKER BELLS



Cha-Cha (High)  
BCM-3NY

Cha-Cha (Low)  
BCM-5NY

Mambo  
BCM-7NY

Marc Quiñones  
Sig. Timbale Bell  
BCM-8NYQ

### BALA BELLS



Mounted  
Campana Bell  
BCM-10

Hand-Held  
Campana Bell  
BCH-10

### AGOGO & TRIBELLS



Tri Agogo  
PTA-30

Pro  
Cowbell Beater  
PDC-60

Dual  
Cowbell Beater  
PDC-10

### PRIMERO COWBELLS



10" Bell w/ PPS30  
PCB-1030

6" Bell  
PCB-6

4" Bell  
PCB-4

8" Guiro Cowbell  
PCB-10GR

10" Millennium Chrome Bell  
PCB-10MCR

10" Anarchy Bell  
PCB-20



# DJEMBES

Ancient Instruments for the Modern Percussionist

## TOP TUNED DJEMBES

<b>PBJV-8</b>	8" x 16"	<b>PBJV-12</b>	12" x 24"
<b>PBJV-10</b>	10" x 19.5"	<b>PBJV-14</b>	14" x 25.75"



#685 Artisan Straight Grain Limba



#686 Artisan Weathered Oak



#684 Artisan Cypress



#685 Artisan Straight Grain Limba



#696 Purple Haze



#697 Tribal Fire



#698 Zebra Grass



#699 Molten Scarlet

## ROPE TUNED DJEMBES

<b>PBJVR-7</b>	7" x 12.5"	<b>PBJVR-12</b>	12" x 24"
<b>PBJVR-10</b>	10" x 19.5"	<b>PBJVR-14</b>	14" x 25.75"



#684 Artisan Cypress



#685 Artisan Straight Grain Limba



#698 Zebra Grass



#699 Molten Scarlet

DJEMBES are a traditional African instrument that offer a wide variety of sounds and are perfect for drum circles.



**Mahogany Djembe**  
12" Hand Carved  
#695 Malinke Village  
**PBJWR-12**

**Field Percussion Djembe**  
14" (Fiberglass)  
#649 Textured Black  
**PJF-350FP**

**Elite Oak Djembe**  
12.5"  
#511 Natural  
**PJW-340**

**Elite Fiberglass Djembe**  
#602 Bistre Black  
**PJF-350** 14"  
**PJF-320** 12.5"

**Fiberglass Fun Drum**  
**PFD-300**

**Djembe Stand - Fits 8" to 14" Pearl Rope Tuned and Top Tuned Djembes**  
**PBJ-STD**

### DJEM-BASS



**PJBs-350**  
Djem-Bass

The **PJBs-350** Djem-Bass Attachment allows you to convert any Pearl 14" djembe into a sub-sonic bass drum. To reduce the attack and add greater "lows," we have included a cloth cap that stretches around the head. For smoother low-end with a slightly reduced attack, slip the included neoprene disc inside, allowing for two distinct sound options. A pedal (not included) attaches via an I.S.S. clamp to the djembe's stand mounting plate. Includes two legs with mounting hardware, pedal bracket, head cover and neoprene muffler.

# FOLKLORIC

## FOLKLORIC ELITE CONGAS

Pearl's Folkloric line of congas feature a traditional look with modern innovation that only Pearl can deliver. Each 28" tall Oak drum is designed for the "seated" player, but includes stand mounts for players who prefer to stand. Thicker South American-style natural skin heads make the drums warm-sounding, but a fiberglass gel coating on the interior seals the shell and add the projection and volume desired by today's players. Four Polished Steel Reinforcing Bands are inset on the shell for a smooth touch, and the traditional hoops complete these stunning Cuban instruments.



**Folkloric Elite Bongos 7" & 8.5"** **PBW-300FC**  
**Tumbador 12.5"** **PCW-125FC**  
**Qunito 11"** **PCW-110FC**  
**Segundo 11.75"** **PCW-117FC**  
#526 CRIMSON SUNRISE



**Uno** **PSK-50FC**  
**Segundo** **PSK-60FC**  
**Caja** **PSK-70FC**  
**10" Segundo Shekere** **PBSK-70**  
**Fiberglass Shekere** **PSK-10**

## BATS

Bata drums originated in Nigeria over 500 years ago and were primarily used for religious purposes. The drums were introduced into Cuba by slaves in the 1820's. Pearl Batas are modeled after an ancient Cuban design and feature naturally finished 100% Thai Oak shells for outstanding and authentic tone. Polished steel traditional rims offer excellent tuning integrity and ease of tuning. These prized ceremonial drums have an hourglass shape and produce a great, warm tone similar to a bongo-like sound on the high drum and a djembe-like tone on the large drum.



**Itotele** **PBA-60**  
**Oconcolo** **PBA-50**  
**Iya** **PBA-70**



**Wood Clave** **PCL-20FCW**  
**Bamboo Clave** **PCL-10FCB**  
**Shekere Holder** **PPS-45**  
**Guataca** **PGT-10FC**  
**Cata w/ Holder** **PCA-14FC**

# BRAZILIAN

## BRAZILIAN PERCUSSION

Modern refinements and Pearl quality to the traditional Samba musician.

The Timbao is made from lightweight fiberglass, and is capable of the extremely high tension utilized in tradition Brazilian ensembles. The lightweight wood shell Surdos allow for hours of comfortable play when worn over the shoulder with the provided strap. Available in 18"x22", 20"x18" and 22"x22" sizes (diameter x depth), Pearl's popular Surdos continue to be the industry standard.

Our Repinique features lightweight yet sturdy steel shells with etched heads, shoulder straps and low rims for incredible playing comfort.



**Timbao** **PBTB-140**  
**Tan Tan** **PBTA-1420**  
**Surdo 20"** **PBS-2018**  
**Surdo 18"** (Shown with optional PBS30BD) **PBS-1822**  
**Surdo 22"** **PBS-2222**  
**Legs & BD Adapter Kit For Surdo** **PBS-30BD**



**Tamborim Stick** **PBT-70S**  
**PBSM-20** **Surdo Mallet**  
**PBCX-1204** **Caixa 12"x4"**  
**PBCX-1265** **Caixa 12"x6.5"**  
**PBC-80SS** **Caixa**



**Repinique 10" w/ Strap** **PBR-10S**  
**Repinique 12" w/ Strap** **PBR-12S**  
**Pandeiro 10"** (5 Sets Platinillas & Goatskin Head) w/ Bag **PBP-510**  
**Pandeiro 12"** (6 Sets Platinillas & Plastic Head) w/ Bag **PBP-612**  
**Pandanza w/ Agogo Bell** **PDZ-510**  
**Tamborim w/ Quick Draw Mount** **PBT-60C**

# CAJONS

Get in the Cajon Zone!

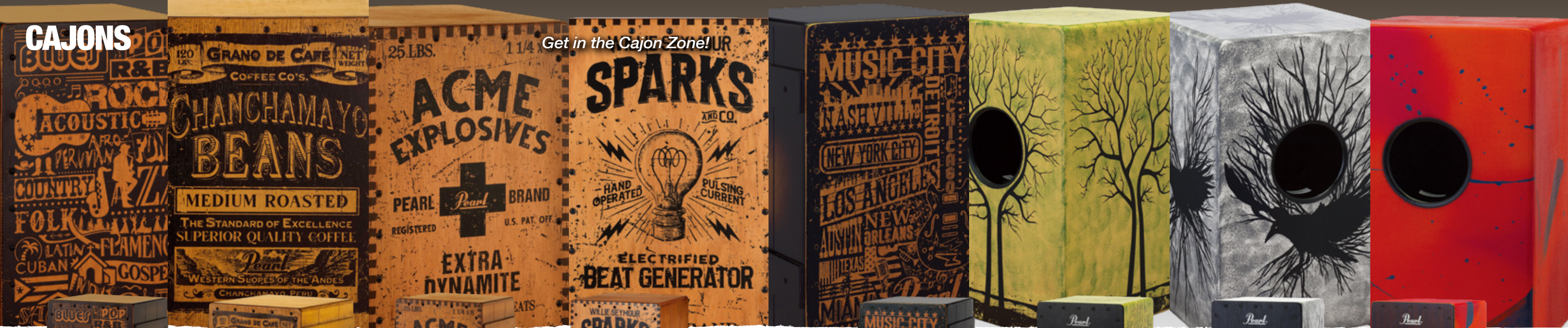

19.25" T x 11.75" W x 11.75" D

### Primero Music Genre Cajon PBC-124B

FACEPLATE	Meranti
BODY	Medium-Density Fiberboard
SNARES	Fixed, two sets
BASS PORT	Patented, built in, rear facing
FINISH	Crate style body with graphic faceplate



TWO SETS SNARES

Features Pearl's crate design and the faceplate displays the names of some of the most popular musical genres.

18.25" T x 14" W x 14" D

### Primero Coffee Bean Cajon PBC-320

FACEPLATE	Meranti
BODY	Meranti Plywood
SNARES	Fixed, three sets
BASS PORT	Patented, built in, rear facing
FINISH	Crate style body with graphic faceplate



THREE SETS SNARES

The Coffee Bean cajon features Pearl's crate design and the faceplate resembles a crate of Peruvian coffee beans.

19.25" T x 11.75" W x 11.75" D

### Primero Acme Cajon PBC-125B

FACEPLATE	Meranti
BODY	Meranti Plywood
SNARES	Fixed, two sets
BASS PORT	Patented, built in, rear facing
FINISH	Crate style body with graphic faceplate



BASS PORT

The Acme Explosive cajon features Pearl's crate design and the faceplate resembles a crate of explosives.

19.25" T x 11.75" W x 11.75" D

### Willie S. Sparks Electric Cajon PBEC-210

FACEPLATE	Meranti
BODY	Meranti Plywood
SNARES	Fixed, two sets
BASS PORT	Patented, built in, rear facing
FINISH	Wood body with graphic faceplate



1/4" JACK

Plug in your cajon with a 1/4" jack and amplify the sound of your Willie Seymour Sparks electrified beat generator.

19.25" T x 11.75" W x 11.75" D

### Primero Music Town Cajon PBC-122B

FACEPLATE	Meranti
BODY	Medium-Density Fiberboard
SNARES	Fixed, two sets
BASS PORT	Patented, built in, rear facing
FINISH	Crate style body with graphic faceplate

The Music Town USA cajon is designed to resemble a wooden crate and the faceplate features the names of some of America's iconic music cities.

19.25" T x 11.75" W x 11.75" D

### Primero Tree of Life Cajon PBC-123BTR

FACEPLATE	Meranti
BODY	Medium-Density Fiberboard
SNARES	Fixed, two sets
BASS PORT	Patented, built in, rear facing
FINISH	Hand painted and silkscreen Tree of Life

The Tree of Life cajon features a hand painted and silkscreen design that wraps around three sides and depicts the Tree of Life.

19.25" T x 11.75" W x 11.75" D

### Primero Raven Cajon PBC-123BBR

FACEPLATE	Meranti
BODY	Medium-Density Fiberboard
SNARES	Fixed, two sets
BASS PORT	Patented, built in, rear facing
FINISH	Hand painted and silkscreen black raven

The Raven cajon's finish is a hand painted and silkscreen design that wraps around 3 sides featuring a stylized black raven.

19.25" T x 11.75" W x 11.75" D

### Primero Abstract Red Cajon PBC-120B

FACEPLATE	Meranti
BODY	Medium-Density Fiberboard
SNARES	Fixed, two sets
BASS PORT	Patented, built in, rear facing
FINISH	Abstract Red body with black faceplate

Its unique finish is an abstract red print on a cloth sarong that is applied to the body of the cajon and is accentuated by the ebony front.



19.25" T x 11.75" W x 11.75" D

### Primero Figured Cherry Cajon PBC-121B

FACEPLATE	Figured Cherry
BODY	Medium-Density Fiberboard
SNARES	Fixed, two sets
BASS PORT	Patented, built in, rear facing
FINISH	Natural Figured Cherry w/ gloss black body

Features a stunning figured Cherry faceplate. Because of its hardness, tonally cherry is a close match to maple and when used on a cajon provides more bottom-end.



18.75" T x 12.5" W x 12.5" D

### Jingle Cajon PCJ-629

FACEPLATE	Asiatic hardwood
BODY	Fiberglass
SNARES	Fixed, three sets
BASS PORT	Rear facing
FINISH	#616 Artisan Wood Grain

Simply twist open the Brazilian Platinella-style jingles and a new world of sonic options open up, as you sound like two percussionists blending simultaneously.



18.75" T x 12.5" W x 12.5" D

### Boom Box Cajon PCJ-633BB

FACEPLATE	Asiatic hardwood
BODY	Fiberglass
SNARES	Fixed, three sets
BASS PORT	Built in, rear facing
FINISH	#635 Artisan Zebra Wood

The Boom Box Cajon creates never-before-heard low-end frequencies from a Fiberglass cajon! Features a fixed snare system and a built-in bass port for subsonic frequencies you have to hear to believe!



18" T x 14" W x 14" D

### Primero Bass Boom Cajon PCJ-1418BBM2

FACEPLATE	Meranti
BODY	Medium Density
SNARES	Fixed, three sets
BASS PORT	Built in, rear facing
FINISH	Crimson body with black faceplate

Traditional style, classic look, amazing sound. The Bass Boom cajon will get the job done in style.

## CAJON ACCESSORIES



Cajon Holster Nylon w/ Velcro Straps  
CAJH-100



Seat Cushion w/ Thick Foam. Adds comfort for long sessions.  
PSC-BC



Box Cajon Case 13" x 14" x 20"  
PSC-1213CJ

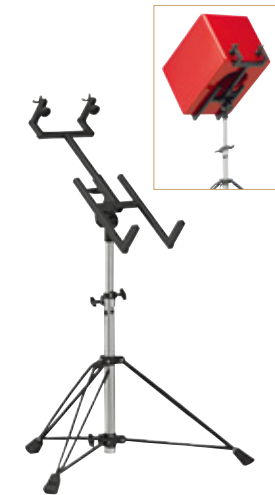

Cajon Stand  
PCJ-70STD

# HANDPANS

A Cosmic Blend of Sound

## MELODIC HANDPAN



22" Melodic Handpan  
9 Note D Minor - Patina Finish  
**PBHP-500**

Handpans are musical instruments that are a subset of the steelpan. The beautiful tonal characteristics will remind you of steel drums, but handpans are only played by hand, with no sticks or mallets, so the sound has reduced attack but is much more mellow.

The shape of Pearl's 22" Awakening Series Melodic and Euphonic handpans feature a center tone field surrounded by eight tone fields. Each tone field has a fundamental note, an octave, and an overtone, so each field has three notes. The hand-crafted steel construction of the instrument is designed so each tone field holds its tuning.

The Melodic handpan features a patina finish and is meticulously tuned to the D Minor scale, and responds to your finger strikes with excellent sonority.



Hand Hammered Tone Field

Rubber Edge Protection

Padded Case Included

## EUPHONIC HANDPAN

The gray Euphonic handpan is designed for budget-conscious players and tuned to F Minor. Both models include a sturdy, PVC reinforced backpack-style bag to protect the handpan during travel and storage. Tabletop and floor stands are also available but sold separately.



Case Included

22" Euphonic Handpan  
9 Note F Minor  
Red Burst Finish  
**PBHP-300 #R (Red Burst)**

22" Euphonic Handpan  
9 Note F Minor  
Gray Lacquer Finish  
**PBHP-300 #G (Gray)**

*NOTE: Items pictured are not to scale*

## HANDPAN ACCESSORIES



Handpan Table Top Stand  
**PTTD-10**

Handpan Floor Stand  
**PBFS-30**

Handpan Case  
**PBHPB-50**

Adjusts from 36"-40" tall

Fits any 20"-22" handpan

# TONGUE DRUMS

Engineered for the Professional Percussionist



## AWAKENING SERIES TONGUE DRUMS

Pearl proudly introduces the Awakening Series of 6 Tongue Drums: Three 8 note and three 9 note drums tuned to pentatonic scales.

Tongue drums derive their name from the tongue shaped areas where you strike the drum. The results are a cosmic blend of tones that are as much fun to hear as play.



8 Note G Major #687 Blue Burst  
**PMTD8GMF**

8 Note A Ake Bono #688 Brown Burst  
**PMTD8AKBF**

8 Note A Minor #689 Green Burst  
**PMTD8AMF**

9 Note C Lydian #690 Orange Burst  
**PMTD9LYDF**

9 Note C Major #691 Crimson Burst  
**PMTD9CPTF**

9 Note C Ake Bono #692 Purple Burst  
**PMTD9AKBF**

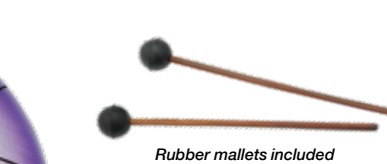

Rubber mallets included

Each drum features a 10" hardened steel shell with precise laser cut tongues for accurate and consistent tuning. Pearl Tongue drums can be played with your fingers or with a set of mallets included with each drum.

9 Note C Ake Bono  
#692 Purple Burst  
**PMTD9AKBF**

## TONGUE DRUM BAG



Tongue Drum Bag  
**PTDB-10B**

# AWAKENING SERIES

## Rainsticks and Nut Shakers

### RAINSTICKS

#### BAMBOO RAINSTICKS WITH BURNED FINISH #694 RHYTHM WATER



Pearl's natural Bamboo Rainsticks are 2.5" in diameter and feature an internal spiral maze of tines that a cascade of lava pebbles flow over to create the soothing sound of falling rain.

Pearl has expanded its line of shakers to include six Bamboo rainsticks ranging in size from 16" to 60" and available in two unique finishes.



#### BAMBOO RAINSTICKS WITH PAINTED FINISH #693 HIDDEN SPIRIT

### NUT SHAKERS

The Awakening Series has been expanded to include a series of natural nut shakers that provide earthy tones that complement the series. Kenari, Bendo, and Pangi nuts range in size from small, medium, and large and each size

possesses unique sound properties. From the recording studio to the yoga studio Pearl's Awakening Series has an instrument and sound that will inspire you.



Pangi Nut Shaker w/ Rope Handle  
**PBGRH14**

**20 INDIVIDUALLY STRUNG PANGI NUTS**  
Deeper, earthy tone.



Pangi Nut Shaker w/ Bamboo Handle  
**PBGBH12**

**BAMBOO HANDLE**  
Gives player more control.



Bendo Nut Shaker w/ Rope Handle  
**PBBSKRH**

**16 STRANDS OF BENDO NUTS**  
Bright, woody tone.



Kenari Nut Bracelet Shaker  
**PBGLKEN**

**14 HAND STRUNG KENARI NUTS**  
Worn to layer sounds.



**PBKENCH01**  
26 Kenari Nut Wind Chime \*Clamp not included

**MAHOGANY CROSS BAR**  
Suspended nuts for unique earthy sounds.



Kenari Nut Shaker 7"  
**PBSHKENL**

**22 STRANDS OF KENARI NUTS**  
Full, robust tone.

# CONCERT PERCUSSION

Engineered for the Professional Percussionist



Pearl is proud to offer Concert Percussion instruments that are attractively priced for school ensembles, yet engineered with the professional percussionist in mind. The symphonic tambourine is a perfect example. Its 17 pairs of specially aged, stamped brass jingles provide a dry, yet bright tone that brings added color to any musical situation. Its 10" headed wood frame allows the

player to effortlessly perform all tambourine techniques, and the tambourine's plush carrying case is included. The rattler is another vital component to any concert percussionists' equipment, and Pearl's is built with an extended handle for a comfortable grip and ease of playing. Holders for the rattler and castanets are also available.



Mix Copper And Brass  
**PETM-1018CR**

Mix Copper and Bronze  
**PETM-1018CB**

Mix German Silver and Copper  
**PETM-1018GC**

Beryllium Copper  
**PETM-1018CP**

German Silver  
**PETM-1018GS**

### ORCHESTRAL TAMBOURINES

The Pearl Orchestral Series Professional Tambourines provide performers a new voice and sound for any performing situation. These 5 instruments feature uniquely sourced and hand-

hammered jingles combinations of German Silver, Phosphor Bronze, Beryllium Copper, and Yellow Brass that give a full spectrum of color and projection options to players. The 10" shell is a well-balanced and lightweight 2-ply Mahogany

design with contoured hand-hold areas for comfortable performance and warm tone. The natural finish goatskin head provides a full responsive sound and traditional look without sacrificing durability.



16" Ocean Drum  
**PSFM-16**

14" Frame Drum  
**PFR-14C**

Frame Drums Set of 6 - Sizes: 8", 10", 12", 14", 16", 18"  
**PFR-0818C**



Castanets (Long Handle)  
**PCN-20**

Castanets  
**PCN-20S**

Castanets Holder  
**PCN-20H**

Slap Stick  
**PSS-100**

Elite Concert Wood Blocks (High)  
**PCWB-100A**

(Medium)  
**PCWB-200A**

(Low)  
**PCWB-300A**

Mounting Bracket incl.

### ELITE TRIANGLES

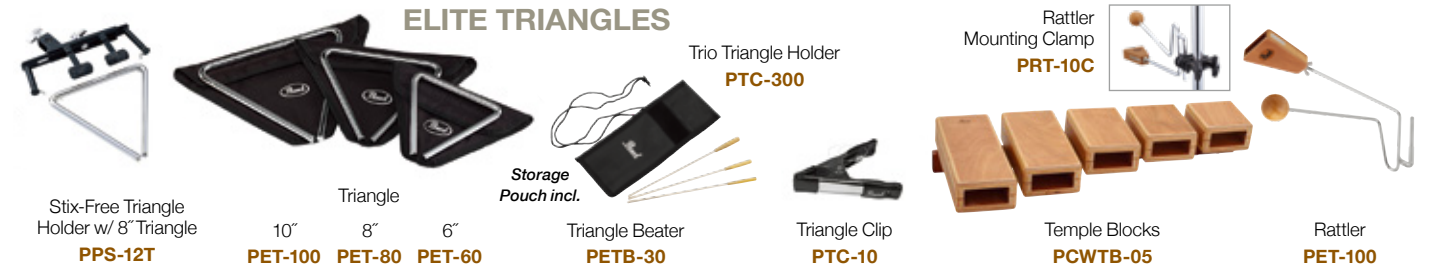

Stix-Free Triangle Holder w/ 8" Triangle  
**PPS-12T**

Triangle  
10" **PET-100**  
8" **PET-80**  
6" **PET-60**

Triangle Beater  
**PETB-30**

Triangle Clip  
**PTC-10**

Rattler Mounting Clamp  
**PRT-10C**

Temple Blocks  
**PCWTB-05**

Rattler  
**PET-100**

# HAND PERCUSSION

A World of Hand Percussion

BLOCKS, BELLS, SHAKERS and more. Choose from a complete selection of hand percussion instruments to add color and impact to your music.



Natural Gourd Guiro  
**PNG-20**

Two scraping surfaces: thin grooves on one side for a lighter sound and thicker cut channels on the other side for a beefier sound. The interior is coated with a fiberglass get to add projection and volume.



Metal Guiro  
**PMG-20**

Perfect for Merengue rhythms, or just a different metallic sound texture, Pearl's Metal Guiro will become an essential ingredient in your "toy" bag. Scraper included.



Fiberglass Guiro  
**PFG-20**

Pearl's Fiber Guiro is light-weight and provides optimal projection due to its fiberglass construction. With the included striker and two different playing surfaces you have a world of sonic possibilities in your hand.



Guiro Holder  
**PGH-20**

This innovative design will hold virtually any size guiro secure for one handed playing. Easily mountable off the lug of your conga or any 3/8" post, Pearl's Guiro Holder uses a track system to lock the guiro in place. Included is a 3/8" "Z" rod so you can also mount your favorite accessory as well.



Beaded Maracas  
**PFM-20**

The Beaded Maracas feature Shekere-style beads which offer an excellent sound with greater control, and foam handles for enhanced comfort.



Maracabasa  
**PFM-50**

The Maracabasa is two great instruments in one, combining the functionality of a maraca and a cabasa in one handheld instrument. Featuring a ribbed fiberglass body wrapped in shekere-style beads.



Basket Ganza 9" X 4"  
**PGA-20**

The Pearl basket ganza is a 9"x4" woven tube containing wooden sticks instead of conventional shot. The wood sticks produce an airy percussion sound.



Shakelets  
**PWR-40**

This innovative percussion item feature exclusive "Ganzinellas", Brazilian-style plantinellas combined with ganza shakers that are worn on the wrists to produce a shaker sound when playing.



Spirit Chimes w/ Holder and Mallet  
**PSC-30BR**

Spirit Chimes have many applications in school bands, percussion ensembles and music programs. They are also perfect for meditation and yoga studios.



36 Anodized Aluminum Chimes w/ Case, Holder, And Striker  
**PWCH-3620A**

- Satin black frame with polished bars
- Self-dampening parallel swinging chimes



32 Gold Anodized Aluminum Chimes w/ Case, Holder, and Striker  
**PWCH-3220G**

- 32 Gold anodized aluminum chimes
- Self-dampening parallel swinging chimes



32 Bar Aluminum Windchimes w/ Case, Holder, and Striker  
**PWCH-3220A**

- 32 Anodized Aluminum Chimes
- Self-dampening parallel swinging chimes



Foldable 36 Anodized Aluminum Chimes  
**PWCHF-3620AF**

- Individually strung, goes from 19.25" to 9.75"
- Self-dampening parallel swinging chimes



Quickmount Tambourine w/ Steel Jingles  
**PTM-10SHX**

Six double rows of premium steel jingles deliver a bright metallic sound. Features a comfort grip handle that slides into the shock-absorbing Quickmount bracket. Mounts to any 3/8" post.



QUICKMOUNT BRACKET  
Hand-held to mounted in seconds.



Quickmount Tambourine w/ Brass Jingles  
**PTM-10GHX**

Six double rows of premium brass jingles deliver with bright and a warm metallic sound. Comfort grip handle that slides into the shock-absorbing Quickmount bracket. Mounts to any 3/8" post.



COMFORT GRIP HANDLE  
Molded ergonomic shape.



**PTM-50BHR** (Brass)  
Ultra Grip Volume Adjustable Tambourine



**PTM-50SHR** (Stainless Steel)

The jingle control discs can be moved to the outside to allow the jingles to ring freely. As the jingle control discs are tightened the more restricted the jingle.

Brass is an alloy of copper and zinc and the jingles provide a bright mid-range tone. Steel jingles have a higher tone with extra top end and sustain.



9" Primero Rock Tambourine w/ Millennium Jingles  
**PTM-09BK**

The Primero Rock Tambourine features 6 double sets of Millennium Chrome Jingles in a matte black oval frame.



Headless Wood Tambourines  
**PTH-10B** (Brass)  
**PTH-10S** (Stainless Steel)

Brass is an alloy of copper and zinc and the jingles provide a bright mid-range tone.



Stainless Steel jingles produce a higher tone with extra top end and sustain.



Hi-Hat Jingle Ring  
**PJH-10SH**

The Hi-Hat Jingle Ring has 20 sets of Stainless Steel tambourine style jingles that will accentuate your Hi-Hat sound with every opening and closing of your cymbals.



Gatting Cabasa  
**CBS-100**

Simply grab the precision handle and fire away to play any pattern you wish, or keep spinning it for an infinite "sizzle" that is not possible with standard Cabasas.

## ASH TONE BLOCKS



Tang-Tang  
**PTG-20**

A high and low pair of unique shakers that incorporate a Caxixi-Style Plate and Wooden "Clacker."



**PAB-20** (High)  
**PAB-50** (Medium)  
**PAB-100** (Low)

Pearl's Ash Tone Blocks are constructed using Ashwood because it is extremely hard and durable. The Ash Tone Blocks are pitched in "thirds" and each block includes a mounting bracket that accepts a 3/8" post.

## CLAVE BLOCKS



**PBL-10** (High)  
**PBL-20** (Medium)  
**PBL-30** (Low)  
**PBL-100** Anarchy Block

Pearl's clave blocks are injection molded so they're virtually indestructible, and the solid color will never chip, fade, or peel. Our exclusive CDV (Chamber Density Variation) Technology process allows all three clave blocks to be the same dimensions but still differ in pitch.

Produces a low piercing pitch that will cut through even the heaviest metal rhythm section.



21" Field Percussion Shaker  
**PGA-60FP**

Hexagonal body and internal chamber for a truly massive sound.



Wood Hex Ganzas  
**PGA-30W** (Short) **PGA-32W** (Long)

The wood Hex Ganzas are made from Shorea wood and maintain the same strong projection as their aluminum brothers, but deliver a warmer less metallic tone.



Hex Ganzas  
**PGA-30** (Short) **PGA-32** (Long)

The Pearl aluminum Hex Ganzas give more sound control than round shakers and produce a lush shake sound due to their hexagonal shape.



Triple Shaker  
**PGA-40**

6" long, rectangular aluminum shaker provides three unique sounds: shake, click, and swish.



Egg Carton  
**PEC-1**

Three egg shakers in a clear tube that can be played separately or as a complete unit.

# STANDS, BAGS, HOLDERS

Pro Tools for Every Gig

## CONGA STANDS



Quick Release Double Conga Stand w/ Bag  
**PC-3000TW**



Quick Release Double Conga Stand  
**PC-300W**



Pro Conga Stand  
**PC-3000**



All-Fit Conga Stand  
**PC-900**



Primero Twin Conga Stand  
**PC-200**



Ultra Lite Conga Stand  
**PC-2500**



Primero Basket Conga Stands  
**PC-100P (10) PC-110P (11)**

The **PC-3000TW** stand holds full size professional congas as securely as most stands double its weight and mass.

The **PC-300W** is scaled down to support our lighter Primero Conga lineup. Both stands setup in seconds because there are no wingnuts needed to mount your congas.

The **PC-2500** Ultralite Conga stand, is lightweight yet sturdy and stable. Index markings on all adjustable parts make for consistent lightning fast setups.

## BONGO STANDS



Pro All Fit Bongo Stand with Spring Loaded Strap Hinge  
**PB-3000**



Bongo Stand for Seated and Concert Player  
**PB-3000S**



All-Fit Tilting Bongo Stand  
**PB-900LW**



Lightweight Bongo Stand  
**PB-700**



Bongo Attachment for PC200  
**PB-700BHS**

## DJEMBE STANDS



All Fit Djembe Stand  
**PC-800S**



Pro Djembe Stand  
**PD-3000**



All-Fit Djembe Stand  
**PC-800S**

HEIGHT: 16" to 21"

## CAJON STANDS



Cajon Stand  
**PC-J70STD**

## TRAP TABLES

Pearl's wide selection of trap tables and accessories feature sturdy and dependable options for any musical situation. Options include a variety of sizes, construction materials, tables with stands, tray tops and table tops only and single or double braced legs.

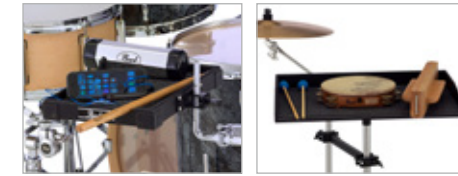

Trap Table Single Braced (18" x 24")  
**PTT-1824**

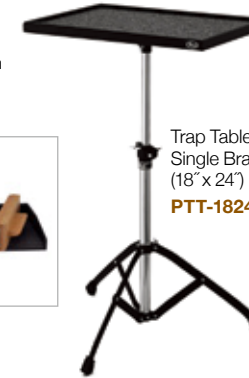

Trap Table Double Braced (18" x 24")  
**PTT-1824W**

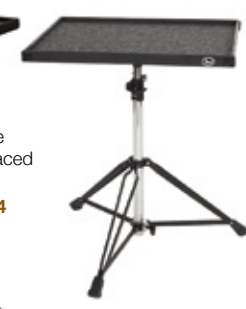

Aluminum Trap Table (15" x 24") w/o Stand  
**PTT-1524MPT**



Aluminum Trap Table (15" x 24") w/ Stand  
**PTT-1524MPW**



Tech Tray (8.5" x 11")  
**PTT-8511**



Trap Table (12" x 12")  
**PTT-1212**

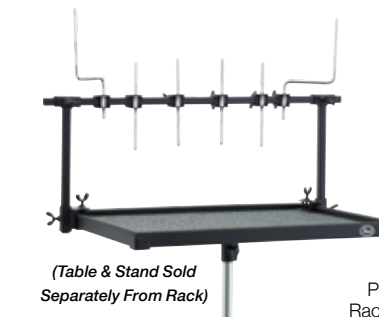

(Table & Stand Sold Separately From Rack)  
Universal Trap Table Rack  
**PTR-UNV**

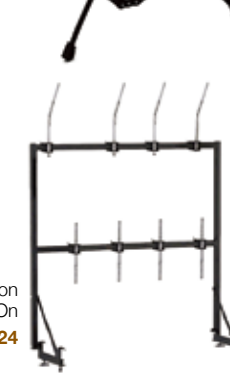

Percussion Rack Add On  
**PTR-1824**



3/8" Straight Post  
**PTR-1824RC1**



3/8" Angled Post  
**PTR-1824RC2**



Post Attachment  
**PTR-1824RC6**



(FOR PTT1824, PTT1212)  
Trap Table Single Post Adapter  
**PTR-1824RC3**

## PERCUSSION CASES

Features include: ergonomic carrying straps, rubber protective bottoms, top-mounted carrying handles, tuning wrench pouches, & heavy duty double zippers.



12" Djembe Bag  
**PBJ-CXL**



14" Djembe Bag  
**PBJ-CXXL**



Box Cajon Case 13" x 14" x 20"  
**PSC-1213CJ**



Travel Conga Case  
**PSC-1175TC**

## HOLDER & ACCESSORIES



Angled Post Adapter  
**PPS-37**



Lug Mount Accessory Holder  
**PPS-40**



Universal Guiro Holder  
**PGH-20**



Foot Pedal Bracket  
**PPS-20**



Cowbell Stacker  
**PCS-10**



Stix-Free  
**PPS-10 & PPS-11**



Percussion Toy Box (Accessories Not Included)  
**PTYB-1212**

## COWBELL HOLDERS



**CA-130**



**75-H**



**75-X**



**PPS-81**



**PPS-82**

NOTE: Items pictured are not to scale

# REPLACEMENT PARTS

Pearl offers a tremendous number of parts for our drums and hardware. The parts represented on these pages are some of the most commonly requested items.

## MASKING COVERS & MOUNTING BRACKET

The GK-90 and BBC-1 cover the holes of BT-3 and BB-3 brackets that have been removed.



GK-90



BT-3

- BBC-1** For BB3, w/Gasket, Screws and Nuts
- GK-90** For BT3, inside/outside plates w/ Bolts
- BT-3** Tom Tom Bracket

## BASS DRUM HOOP PROTECTORS



- HPP-2** Metal Hoop Protector for Wood BD Hoops
- NP-01** Hoop Protector for Metal BD Hoops
- NP-347/2** Non-Slip Hoop Protector for Wood BD Hoops (pair)

## P2050 SERIES CAMS



### ELIMINATOR OPTION CAM

- CAM-PL** Purple Cam, Aggressive Action
- CAM-YL** Yellow Cam, Inverse Action
- CAMT-BK** Translucent Black Cam, Linear Action
- CAMT-WT** Translucent White Cam, Oversized Linear Action
- CAMT-BL** Translucent Blue Cam, Progressive Action
- CAMT-RD** Translucent Red Cam, Radical Action

## FLOOR TOM LEGS & BRACKETS



- FTL-07C/3** Floor Tom Legs (3 Legs)
- LG-40L/3** Long Floor Tom Legs (3 Legs)
- LB-40** Leg Bracket for PMX, STS
- LB-75** Leg Bracket for RF1, MMG, MM6, MP4, PSD

## HI-HAT CLUTCHES & PARTS

### RAPID LOCK HI-HAT CLUTCHES

Hi-Hat set-up and tear-down is a breeze with Rapid-Lock's Patented\* two-point quick release locking system. \*U.S. Patent #9355625

- HCL-205DQR** Rapid Lock Quick Release Hi-Hat Drop Clutch w/ Locking Nut
- HCL-205QR** Rapid Lock Quick Release Super Grip Hi-Hat Clutch w/ Locking Nut
- HCL-105QR** Rapid Lock Quick Release Hi-Hat Clutch w/ Locking Nut
- HCL-79** Hi-Hat Clutch Complete
- HHC-90** Plastic Cup w/ Tilter



## CHAINS & BELTS



- CCA-5** Chain Assy Complete for Eliminator Pedals
- BCA-250** Belt Assy Complete for P-2050 Eliminator Pedals

## SPRING



- SP-64F** Spring for P-930/P-932

## BEATERS & BEATER WEIGHTS



- DB-100** Duo-Beater Felt/Plastic Control Core Quad Beater
- B-250QB** Control Core Quad Beater
- B-350XR** Extreme Impact Beater

### BEATER WEIGHTS

- BW-100** Beater Weight, 3 Weights in One (U.S. Patent #7122730)

## MASTERCAST HOOPS

MasterCast are the finest die cast hoops available and feature the perfect blend of thickness and mass to improve the depth, clarity, and focus of toms and snare drums.



Model #	Diameter	# of Tension
DC-0805	8"	5
DC-1006	10"	6
DC-1206	12"	6
DC-1306	13"	6
DC-1308	13"	8
DC-1308S	13"	8 Snare Side
DC-1408	14"	8
DC-1408S	14"	8 Snare Side
DC-1410	14"	10
DC-1410S	14"	10 Snare Side
DC-1410SG	14"	10 Snare Side w/ Guard
DC-1508	15"	8
DC-1608	16"	8
DC-1808	18"	8

## SUPERHOOP II

SuperHoop II hoops are precision formed from heavy-duty 2.3mm steel, triple-flanged and engraved with the SuperHoop II logo.



Model #	Diameter	# of Tension
SH-0604	6"	4
SH-0805	8"	5
SH-1006	10"	6
SH-1006S	10"	6 Snare Side
SH-1206	12"	6
SH-1208	12"	8
SH-1208S	12"	8 Snare Side
SH-1306	13"	6
SH-1308	13"	8
SH-1308S	13"	8 Snare Side
SH-1408	14"	8
SH-1408S	14"	8 Snare Side
SH-1410B	14"	10
SH-1410S	14"	10 Snare Side
SH-1410SG	14"	10 Snare Side w/Guard
SH-1508	15"	8
SH-1510S	15"	10 Snare Side
SH-1510B	15"	10
SH-1608	16"	8
SH-1808	18"	8

## STEEL HOOPS

Steel Hoop Model #	Diameter	# of Tension
RH-0804	8"	4
RH-1006	10"	6
RH-1206	12"	6
RH-1306	13"	6
RH-1408	14"	8
RH-1408S	14"	8 Snare side
RH-1608	16"	8
RH-1808	18"	8



## BASS DRUM PEDAL TRAINING PAD

The BD-10 bass pad is perfect for practicing at home or on the road. The wide pad accommodates double pedals and is specially formulated for extremely low noise and a realistic feel. The universal-fit "hoop" accepts all brands of pedals and adjusts to compensate for different floor surfaces. The BD-10 folds for compact transport.



BD-10

## QUICK RELEASE WINGLOC



- WL-230** Quick Release WingLoc
- WL-230A** Quick Release WingLoc Complete

## SEAT CUPS AND FELTS



- RC-20** Reversible Seat Cup, w/ O-Ring (U.S. Patent #6940006)
- PL-11** Cymbal Seat Cup
- FLW-001/2** Cymbal Felt Washer (2 Pieces)
- FLW-003** Hi-Hat Cup Felt Washer

## STOP LOCK



- ZD-081A** Stop Lock Complete

## DRUM KEYS



- KGT-100H** Gyro Tune Key w/ Quick Release
- K-030** Hi-Tension Tuning Key
- K-080** Tuning Key

## AIR SUSPENSION FEET



- R-40/3** Air Suspension Rubber Feet (3 Each)
- R-5/3** Rubber Tip (3 Each)



RF ONE / MASTERS SHOWN WITH MASTERCAST HOOPS



PROFESSIONAL SERIES SHOWN WITH SuperHoop II HOOPS

## LUGS

- CL-05** Lug for 3" Piccolo Snare
- CL-55** Lug for 5" & 5.5" Deep Snare
- CL-65** Lug for 6" & 6.5" Deep Snare
- CL-100** Lug for over 7" & 8" Deep Snare



# REPLACEMENT PARTS

Pearl offers a tremendous number of parts for our drums and hardware. The parts represented on these pages are some of the most commonly requested items.

## OPTI-LOC



OPL1016/C

Opti-Loc suspension tom holders provide exceptional stability while greatly improving resonance and sustain. (For EXX / DMP)

- OPL-0608/C Opti-Loc for EXX and DMP 6"-8" Diameter
- OPL-1016/C Opti-Loc for EXX and DMP 10"-16" Diameter

## R2 AIR & OPTIMOUNT

To attain tonally true sound, every drum would have to be mounted in a floating point at the center of its shell. R2 Air equally balances mounting pressure across two floating points at the top and bottom of each tom. This gives true tonal separation from mounting hardware and enhances sonic output. U.S. Patent #11640814



R2AS-10-0708C

## JUNGLE GIG



JG-16

JG-16 • Pearl's Jungle Gig allows the conversion of a 16" Floor Tom to a Bass drum.



Our OptiMount Suspension System attaches to the tom's tension rods and floats on rubber cushions, providing the ultimate in stability while allowing the drum to resonate fully without restriction.



OPT-0708 OPT-0910 OPT-1112



OPT-1314 OPT-1516

- OPT-0708 / for drums 7"-8" deep, 8"-16" diameter
- OPT-0910 / for drums 9"-10" deep, 8"-16" diameter
- OPT-1112 / for drums 11"-12" deep, 8"-16" diameter
- OPT-1314 / for drums 13"-14" deep, 8"-16" diameter
- OPT-1516 / for drums 15"-16" deep, 8"-16" diameter

## MUFFLERS

External clamp-on muffler for snare drums and toms. By adjusting the pressure and position of the felt pad, excessive overtones can be precisely controlled or eliminated.



OM-1

- OM-1 Clamp-on Muffler, Snare Drum & Toms

## MUFFLE HEADS

Model #	Size	Model #	Size
MFH-08	8"	MFH-14	14"
MFH-10	10"	MFH-16	16"
MFH-12	12"	MFH-20B	20"
MFH-13	13"	MFH-22B	22"

## BASS DRUM MUFFLER



BDM-F

- BDM-F Bass Drum Muffler (Full Size)
- BDM-M Bass Drum Muffler (Mini Size)

## TENSION ROD LOCKNUTS



TNK-10N/10

TL-20/10

- TNK-10N/10 Tension Keeper (10/pkg)
- TL-20/10 Tension Rod Lock Nuts (10/pkg)

## TENSION ROD WASHERS



NLW-12B/12

MTW-12/12

- NLW-12B/12 Nylon Washers (12) Black
- MTW-12/12 Metal Washers (12)

## STRAINERS



SR-017

- SR-014N Standard Snare Strainer
- SR-017 Snare Strainer Complete
- SR-018 Snare Strainer Complete



ON

OFF

**THE SR-017 STRAINER** Simple and effective, the SR017 is a Pearl standard for effortless snare switching and sensitivity control. Its smooth lever action and fine-tuning knob let you dial in the right amount of snare wire saturation to suit your personal sound.

## ULTRA-SOUND SNARES

Pearl's Ultra-Sound snares feature patented Graduated Tension wires for extended dynamic range from ultra soft to ultra loud. Ultra-thin, low mass end plates assure ultra quick response. The end plates feature three mounting options: tunnels or holes for cord mounting and slots for straps. U.S. Patent #7202405

20 / I 20 / D 20 / C



- SN-1320C 20 strands for 13", C-type, w/ straps & cords
- SN-1320D 20 strands for 13", D-type, w/ straps & cords
- SN-1320I 20 strands for 13", I-type, w/ straps & cords
- SN-1420C 20 strands for 14", C-type, w/ straps & cords
- SN-1420D 20 strands for 14", D-type, w/ straps & cords
- SN-1420I 20 strands for 14", I-type, w/ straps & cords

42 / I 42 / D 42 / C



- SN-1442C 42 strands for 14", C-type, w/ straps & cords
- SN-1442D 42 strands for 14", D-type, w/ straps & cords
- SN-1442I 42 strands for 14", I-type, w/ straps & cords

## REPLACEMENT SNARES



SPS-18/6  
SNC-500R/4

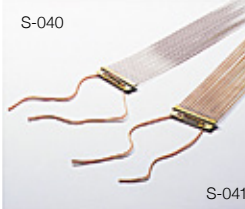

S-040

S-041

- S-022N 20 Strand for 14" w/ Cords
- S-022NU 20 Strand for 14" w/ Cords, Uncoated
- S-022 20 Strand for 14" w/ Straps
- S-025 20 Strand for 14" long, w/ Straps
- S-029N 20 Strand for 13" w/ Cords
- S-030N 24 Strand for 14" w/ Cords
- S-031N 20 Strand for 12" w/ Cords
- S-032N 16 Strand for 10" w/ Cords
- S-033N 16 Strand for 12" w/ Cords
- S-040 15 Strand for 14" w/ Cords, Steel Cable, Thinner Gauge
- S-041 15 Strand for 14" w/ Cords, Bronze Cable, Thicker Gauge
- SPS-18/6 Plastic Strap (6/pkg)
- SNC-500R/4 Snare Cord (4/pkg)

## STAINLESS STEEL TENSION RODS

Pearl's Stainless Steel Tension Rods are machined, not forged, from a single piece of stainless steel to the most exacting tolerances in the industry. They feature super-smooth, precise tensioning, with absolutely no play. Each non-plated stainless steel tension rod is matched with a precision-machined brass swivel nut for ultra-precise performance.



- SST-5028/6 W7/32 x 28mm (6)
- SST-5035/6 W7/32 x 35mm (6)
- SST-5038/6 W7/32 x 38mm (6)
- SST-5042/6 W7/32 x 42mm (6)
- SST-5047/6 W7/32 x 47mm (6)
- SST-5052/6 W7/32 x 52mm (6)
- SST-6115 M6 x 115mm

## TENSION RODS

- T-055/6 W7/32 x 28mm (6) for 3" Deep Snare
- T-060/6 W7/32 x 35mm (6) for Free Floaters before 2002
- T-061/6 W7/32 x 42mm (6)
- T-061L/6 W7/32 x 47mm (6) for 6.5" Deep Snare
- T-062/6 W7/32 x 52mm (6) for 5.5" Deep Snare
- T-065 M6 x 90mm (Bass Drum)
- T-066 M6 x 115mm (Bass Drum)
- TR-5052 W7/32 x 52mm (DMP, EXX, MDT Snare)
- TR-5047 W7/32 x 47mm (DMP, EXX, MDT Toms)
- TR-5100 W7/32 x 100mm (Bass Drum)



T-055/6

T-060/6

T-061/6

T-061L/6

T-062/6

T-065

T-066





 <b>A-YEON</b> Independent	 <b>A. SIVAMANI</b> Independent	 <b>AARON SMITH</b> Independent	 <b>ADAM TOMNARD</b> OrlandoDrummer	 <b>ADRIAN BENT</b> Drake	 <b>BRIAN FRASIER-MOORE</b> Justin Timberlake / Pink
 <b>ALEX HOLZWARTH</b> Turilli / Lione Rhapsody	 <b>ALEXANDRE APOSAN</b> Independent	 <b>ALVIN FORD</b> Trombone Shorty	 <b>AREJAY HALE</b> Halestorm	 <b>BRIAN FRASIER-MOORE</b> Justin Timberlake / Pink	 <b>BRIAN FRASIER-MOORE</b> Justin Timberlake / Pink
 <b>DENNIS CHAMBERS</b> Drumming Legend	 <b>ARIEN VAN WESSENBREEK</b> Epic4, MaYan	 <b>CASEY COOPER</b> @COOP3RDUMMR	 <b>AUSTIN BURCHAM</b> ABDRUMS	 <b>BAARD KOLSTAD</b> Leprous	 <b>BARRY KERCH</b> Shinedown
 <b>BEN GORDON</b> Parkway Drive	 <b>BEN JOHNSTON</b> Biffy Clyre	 <b>BHUSHAN AMATYA</b> Independent	 <b>ERIC SINGER</b> KISS	 <b>ERIC SINGER</b> KISS	 <b>ERIC SINGER</b> KISS
 <b>BILLY HART</b> Jazz Legend	 <b>BRANDON COMBS</b> Leon Bridges	 <b>CALVIN RODGERS</b> Independent	 <b>BRANDON PERTZBORN</b> Suicidal Tendencies	 <b>ERIC SINGER</b> KISS	 <b>ERIC SINGER</b> KISS
 <b>GRIGORI STRIBULSKY</b> Mitski	 <b>BRUNO VALVERDE</b> ANGRA	 <b>CAMPBELL PHILLIPS</b> Oz Drumlina	 <b>GARY HUSBAND</b> Independent	 <b>CHAD CROMWELL</b> Independent	 <b>CHAD SEXTON</b> 311
 <b>GENE HOGLAN</b> Testament / Dethklok	 <b>DANIEL ERLANDSSON</b> Arch Enemy	 <b>CHOI, KI-WOONG</b> Lee Seung-Wan Band / Independent	 <b>CHARLIE ENGEN</b> Five Finger Death Punch	 <b>CHINA DE CASTRO</b> Independent	 <b>CHINA DE CASTRO</b> Independent
 <b>GENE HOGLAN</b> Testament / Dethklok	 <b>DANIEL ERLANDSSON</b> Arch Enemy	 <b>CHOI, KI-WOONG</b> Lee Seung-Wan Band / Independent	 <b>DANI LOBLE</b> HELLOWEEN	 <b>GOBY DICKINSON</b> NORTH MISSISSIPPI ALLSTARS	 <b>GOBY DICKINSON</b> NORTH MISSISSIPPI ALLSTARS

 <b>FLO MOUNIER</b> Cryptopsy	 <b>DANIEL FURNARI</b> Polaris	 <b>DARION JA VON</b> Doja Cat	 <b>DARSHAN DOSHI</b> Independent	 <b>DARSHAN DOSHI</b> Independent	 <b>DARSHAN DOSHI</b> Independent
 <b>DAVE HALEY</b> Psychotic	 <b>DAVE HALEY</b> Psychotic	 <b>DEE SILVA</b> Ludmilla	 <b>HORACIO HERNANDEZ</b> Latin Legend	 <b>DENA TAURIELLO</b> Rob Thomas / Head Over Heels	 <b>DENA TAURIELLO</b> Rob Thomas / Head Over Heels
 <b>DESMOND DAVIS</b> Mickey Guyton	 <b>IAN PRICE</b> Deep Purple	 <b>JUSTIN STEINKE</b> SIXX: AM	 <b>FREDD ORTIZ</b> Los Lobos	 <b>GABE HELGUERA</b> I Prevail	 <b>GABE HELGUERA</b> I Prevail
 <b>GAROR DORNYEI</b> Thunder Duo / Independent	 <b>GE WEI BIN</b> Independent	 <b>GINO BANKS</b> Independent	 <b>GRANT COLLINS</b> Independent	 <b>ELISE TROUW</b> Independent	 <b>JASON BITTNER</b> Overkill / Shadows Fall
 <b>GREG HUTCHINSON</b> Independent	 <b>GREGORY DANIEL</b> Brian McKnight	 <b>JASON BOWLD</b> Bullet For My Valentine	 <b>GREYSON NEKRUTMAN</b> Independent	 <b>JASON BITTNER</b> Overkill / Shadows Fall	 <b>JASON BITTNER</b> Overkill / Shadows Fall
 <b>HARRY JAMES</b> Thunder / Magnum	 <b>HARRY MIREE</b> Hardy	 <b>JASON BOWLD</b> Bullet For My Valentine	 <b>INFERNO</b> Behemoth	 <b>ISAAC JAMBA</b> Independent	 <b>JAI ROW KAVI</b> Independent
 <b>JAMIE PERKINS</b> The Pretty Reckless	 <b>JASON HARTLESS</b> Tod Nugent / Studio	 <b>JOEY KRAMER</b> Aerosmith	 <b>JAN RECHBERGER</b> AMORPHIS	 <b>GEORGE KOLLIAS</b> Nile	 <b>JASKA</b> Children Of Bodom
 <b>JASON HARTLESS</b> Tod Nugent / Studio	 <b>JOEY KRAMER</b> Aerosmith	 <b>JEFF MARINO</b> Darius Rucker	 <b>JEN LEDGER</b> Skillset / Ledger	 <b>JERROLD SULLIVAN</b> The 4 Corners	 <b>JESSE BOYLE</b> Chase Atlantic

# PEARL ARTISTS

VIEW ALL THE PEARL ARTISTS AT:



 <b>JESSE WANG</b> Independent	 <b>JESSE CARABALLO</b> Marc Anthony	 <b>MIKE WENGRN</b> Disturbed, Fight Or Flight	 <b>JOCKE WALLGREN</b> Amon Amarth
 <b>MATT HALPERN</b> Periphery	 <b>JOE LONGOBARDI</b> The Amity Affliction	 <b>JOE TOMINO</b> Matisyahu / Dub Trio	 <b>JOEY JORDISON</b> In Memoriam
 <b>JOHN LONGSTRETH</b> Origin	 <b>JON LARSEN</b> Volbeat	 <b>JONATHAN MOYER</b> Independent	 <b>JUAN "CARLITO" MENDOZA</b> Independent
 <b>JUNGHOON LEE</b> Independent	 <b>MATT MCGUIRE</b> The Chainsmokers		
 <b>KAI HAVTO</b> Nightwish	 <b>KAN OMSUHPAN</b> Potato	 <b>KANG SOO-HO</b> Independent	 <b>KEIO STROUD</b> Independent
 <b>KRIS MYERS</b> Umphrey's McSee	 <b>KIKO FREITAS</b> Independent	 <b>MIKE MANGINI</b> Dream Theater	 <b>KRIS BOWERING</b> Orville Peck
 <b>LESTER ESTELLE</b> Kelly Clarkson / Sessions	 <b>LI HAD</b> Independent	 <b>LIM YONG HOON</b> Independent	 <b>LESTER ESTELLE</b> Kelly Clarkson / Sessions
 <b>MICHAEL "MOOSE" THOMAS</b> Kill the Lights	 <b>LESTER ESTELLE</b> Kelly Clarkson / Sessions	 <b>LI HAD</b> Independent	 <b>LIM YONG HOON</b> Independent
 <b>MORGAN ROSE</b> Sevendust	 <b>LOUIE PALMER</b> Independent	 <b>MARCUS FINNIE</b> Independent	 <b>SAM LOEFFLER</b> Chevelle
 <b>MARK ALFRED</b> Riverdance	 <b>ROBBY AMEEN</b> Independent	 <b>MARTIN "MARHUS" SKARUPKA</b> Cradle of Filth	 <b>OMAR HAKIM</b> Independent
 <b>MARVIN "SMITTY" SMITH</b> Independent	 <b>OMAR HAKIM</b> Independent	 <b>OMAR HAKIM</b> Independent	 <b>OMAR HAKIM</b> Independent

 <b>MATT ARTS</b> Gov't Mule	 <b>MELVIN BALDWIN</b> Justin Bieber	 <b>MICHAEL CARTELLONE</b> Lynyrd Skynyrd	 <b>TARON LOCKETT</b> Cory Henry And The Funk Apostles	 <b>MICHELLE BAPTISTE</b> Lizzo	 <b>MIGUEL LAMAS</b> Independent
 <b>MIKE MILEY</b> Rival Sons	 <b>MORITZ MUELLER</b> The Intersphere	 <b>NATE MORTON</b> The Voice	 <b>NOAH "WUV" BERNARDO</b> P.O.D.	 <b>OLI BEAUDOIN</b> KATACLYSM	 <b>PETE WEEBER</b> Havok
 <b>PARK YOUNG JIN</b> Sinawe / Baada / Myori	 <b>RAY LOZIER</b> Korn / KXM	 <b>PETAR JANJIC</b> Cory Wong	 <b>SHANNON FORREST</b> Sessions	 <b>RICKY LEWIS</b> The Weeknd	 <b>RICKY LEWIS</b> The Weeknd
 <b>QUINTON "Q" ROBINSON</b> Independent	 <b>RODNEY HOWARD</b> Avril Lavigne	 <b>RODRIGO OLIVEIRA</b> Korzus	 <b>SANO DUAN</b> Independent	 <b>STIX HOOPER</b> Independent	 <b>STIX HOOPER</b> Independent
 <b>SHANE CAALAAS</b> Cosmosquad	 <b>SAMU PAOLICELLI</b> Independent	 <b>TERENCE HIGGINS</b> Tab Benoit / Ani DiFranco	 <b>TAVARIUS JOHNSON</b> Jon McReynolds / Lalah Hathaway	 <b>TONY PALERMO</b> Papa Roach	 <b>TOM HURST</b> Tracy Lawrence / Independent
 <b>SUN YU DONG</b> Independent	 <b>TODD SUCHERMAN</b> Styx	 <b>TRAVIS ORBIN</b> Darkest Hour	 <b>TRE STAFFORD</b> Adelitas Way	 <b>TOMMY PORTIMO</b> Sonata Arctica	 <b>TOMMY PORTIMO</b> Sonata Arctica
 <b>TRACY BROUSSARD</b> Blake Shelton	 <b>TODD SUCHERMAN</b> Styx	 <b>TRAVIS ORBIN</b> Darkest Hour	 <b>TRE STAFFORD</b> Adelitas Way	 <b>TOMMY PORTIMO</b> Sonata Arctica	 <b>TOMMY PORTIMO</b> Sonata Arctica
 <b>TROY WRIGHT</b> Independent	 <b>WANG PENG</b> Independent	 <b>WES LITTLE</b> Independent	 <b>WILL HUNT</b> Evanescence	 <b>ZHANG JIONG</b> Independent	 <b>WILL KENNEDY</b> Yellowjackets / Jazz Legend

# COLOR & CONFIGURATION CHART

## REFERENCE ONE / MASTERS MAPLE GUM / MASTERS MAPLE / MASTERS MAPLE PURE [ PREMIUM FINISH ]



## REFERENCE ONE / MASTERS MAPLE GUM / MASTERS MAPLE / MASTERS MAPLE PURE [ CUSTOM FINISH ]



# COLOR & CONFIGURATION CHART

## REFERENCE ONE / MASTERS MAPLE GUM / MASTERS MAPLE / MASTERS MAPLE PURE [ CONFIGURATION ]

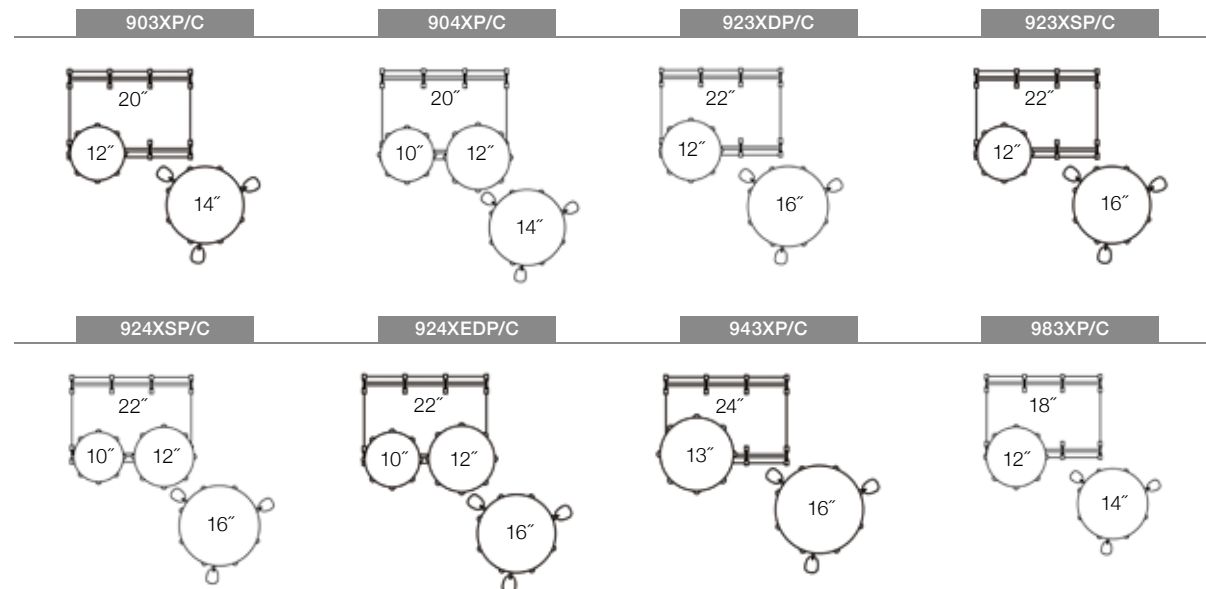

## PROFESSIONAL SERIES AN UPDATED, UPGRADED, PREMIUM GIGGING POWERHOUSE.

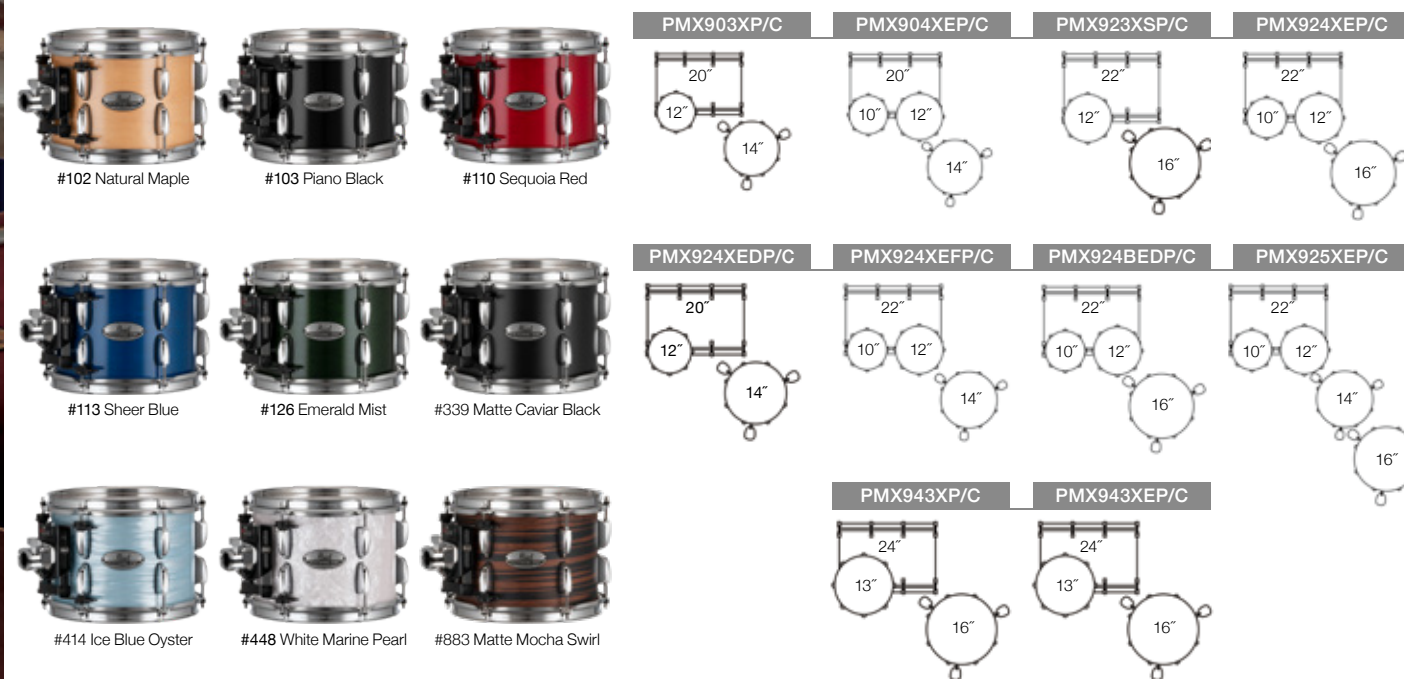

# COLOR & CONFIGURATION CHART

## SESSION STUDIO SELECT AN ALL MAPLE DRUM SHELL FIT FOR THE MASTERS LEGACY.

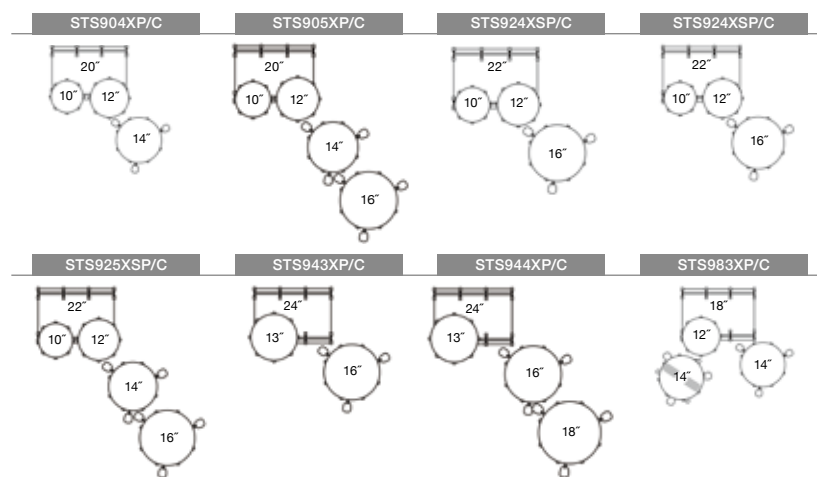

## PRESIDENT SERIES DELUXE A MODERN REVIVAL OF THE DARKLY UNIQUE LAUAN SOUND.

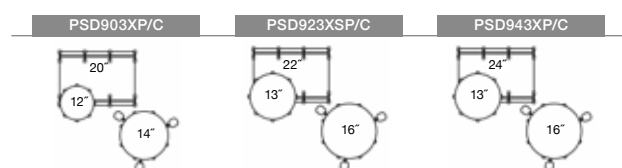

## CRYSTAL BEAT THE ORIGINAL SEAMLESS ACRYLIC DRUM SHELL.

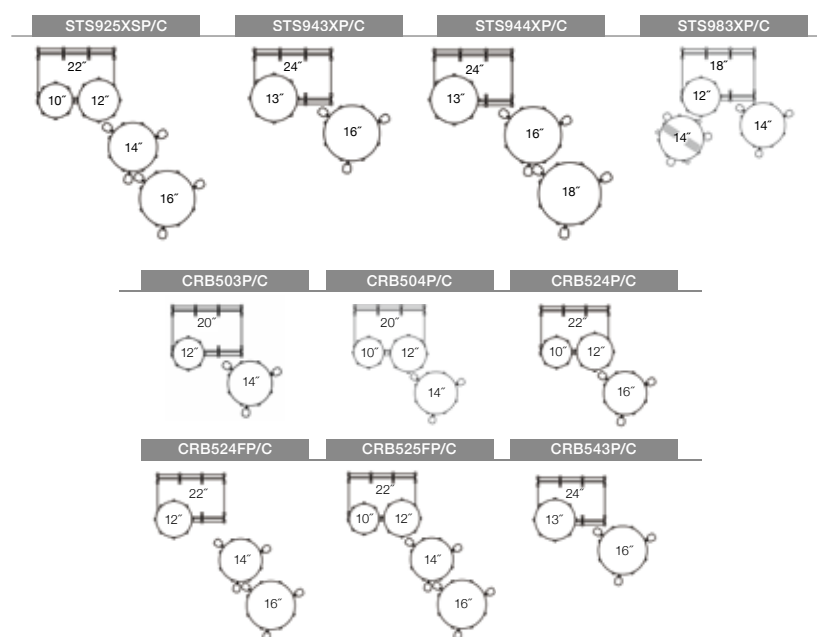

# COLOR & CONFIGURATION CHART

## DECADE MAPLE A DRUM KIT 10 YEARS IN THE MAKING.

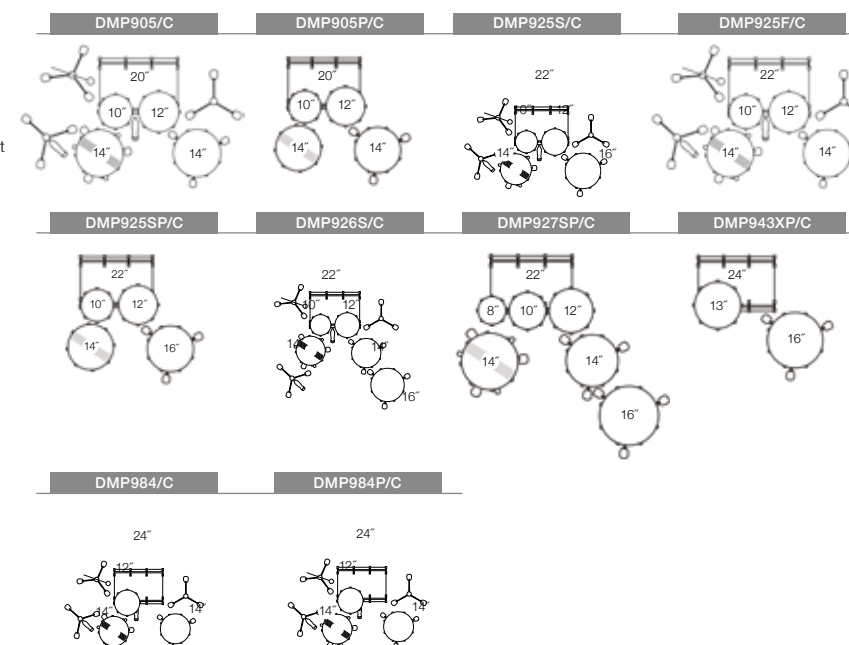

## EXPORT THE BEST SELLING DRUM SET OF ALL TIME.

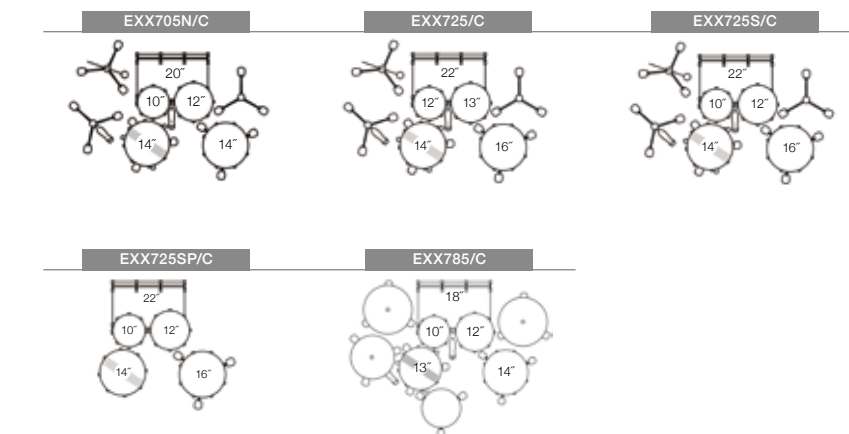

# COLOR & CONFIGURATION CHART

## ROADSHOW IT'S YOUR TIME TO PLAY, START THE RIGHT WAY.



#31 Jet Black



#33 Pure White



#91 Red Wine



#703 Aqua Blue Glitter



#706 Charcoal Metallic



#707 Bronze Metallic



#743 Royal Blue Metallic



#749 Burnt Orange Sparkle

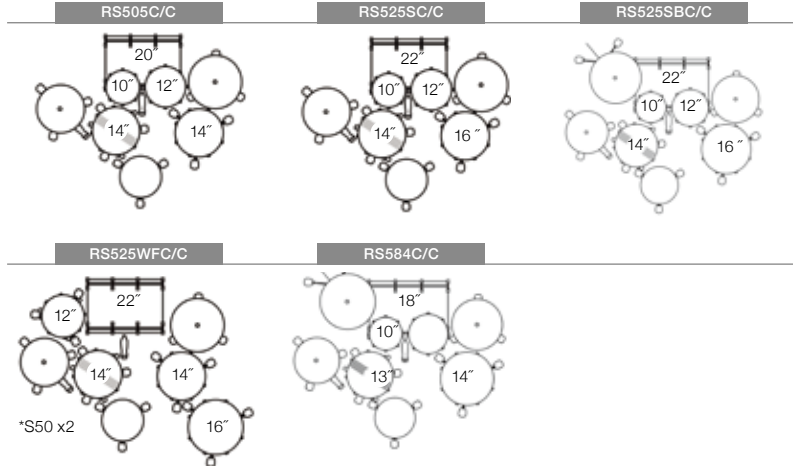

## MIDTOWN BIG GIG, SMALL RIG, HUGE SOUND.



#33 Pure White



#701 Black Gold Sparkle



#704 Black Cherry Glitter

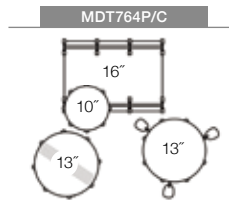

## ROADSHOW JR. COMPLETE WITH HARDWARE, CYMBALS, AND THRONE FOR DRUMMERS UNDER 8.



#31 Jet Black



#33 Pure White



#708 Grindstone Sparkle

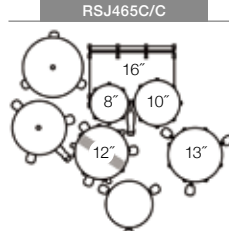

Complete with Hardware, Cymbals, and Throne for Drummers under 8.

## SPECIAL ORDER LACQUER FINISHES

Reference One and all Masters drums are available in two levels of finish choice to best suit your visual preference. Configurable in a host of historic Pearl finishes in Premium and Custom Finish Tiers, Pearl prepares an unprecedented number of configurable shell pack components to give you the features you demand, on demand.

### [ Premium Tier Finishes ]

A host of universally flexible Solid, Transparent Gloss and Satin Lacquer finishes, each using our trademark 52-step lacquering process.

### [ Custom Tier Finishes ]

Visually striking Stripes, Sparkles, Pearloids and other finishes that continue Pearl's legacy of excellence, and tell your rhythmic story with stunning brilliance. Products and specifications are subject to change without notice.

[www.pearldrums.com](http://www.pearldrums.com)

Colors shown in this catalog are for representation only and may not be exactly the same as the original colors due to the printing processes involved.

Products and specifications are subject to change without notice.

item PGC202305

